

DOCUMENT RESUME

ED 231 565

RC 014 090

AUTHOR Robb, Gary M., Ed.
TITLE The Bradford Papers. Vol. III. Proceedings from the 1982 Institute on Innovations in Camping and Outdoor Education with Persons Who are Disabled.

INSTITUTION Indiana Univ., Bloomington. Dept. of Recreation and Park Administration.

PUB DATE 83
NOTE 130p.; Endorsed by the National Therapeutic Recreation Society. Prepared at the Outdoor Education, Recreation and Camping Center located at Bradford Woods, Martinsville, Indiana. For related documents, see ED 224 636-637.

AVAILABLE FROM Indiana University/Bradford Woods, 5040 State Road 67 N, Martinsville, IN 46151 (\$8.00 each; set of vols. 1-3, \$15.00).

PUB TYPE Collected Works - Conference Proceedings (021) -- Reports - Descriptive (141)

EDRS PRICE MF01 Plus Postage. PC Not Available from EDRS.
DESCRIPTORS *Accessibility (for Disabled); Adolescents; Adults; Adventure Education; *Camping; Children; *Disabilities; Exercise; *Experiential Learning; Heterogeneous Grouping; Holistic Approach; Individualized Education Programs; Leadership Training; Mainstreaming; Observation; Orienteering; *Outdoor Activities; *Outdoor Education

IDENTIFIERS Environmental Camp for Handicapped and Others MA

ABSTRACT

Third in a series of papers resulting from the Annual Institute on Innovations in Camping and Outdoor Education with Persons Who are Disabled, this volume consists of 12 articles reflecting innovative efforts to bring exciting outdoor based programs to persons with disabilities. Addressing leadership training, innovative program approaches, and area-equipment-facility accessibility, the articles cover the following topics: the Individualized Education Plan in the outdoor environment as an inservice approach; current practices in training and continuing education; observer tools (e.g., Cheffers' Adaptation of the Flanders Interaction Analysis System and the Individual Response Gestalt) to supplement a program evaluation; cost effectiveness of a 4-day wilderness camping experience for adult acute psychiatric patients; the holistic program at ECHO (Environmental Camp for Handicapped and Others) in Goshen, Massachusetts; the value of heterogeneous groupings for the personal growth wilderness adventure; total physical fitness for persons with disabilities using circuit training (exercises that improve muscle strength, endurance, and flexibility, and cardiovascular endurance); risk training as an educational tool; heritage arts within outdoor education experiences; modifying wheelchairs for compass use; the ropes course at Bradford Woods; and access to recreation for persons with disabilities. The volume concludes with some insights into the Institute's planning and development. (NQA)

6/8/83

ED231565

THE BRADFORD PAPERS

Vol. III, 1983

*Proceedings from the 1982
Institute on Innovations
in Camping and Outdoor
Education with Persons
Who are Disabled*

Edited by
Gary M. Robb
Director of Bradford Woods and Assistant Professor
Department of Recreation and Park Administration
School of Health, Physical Education and Recreation
Indiana University
Bloomington, Indiana

Sponsored by
Indiana University's
Outdoor Education, Recreation and Camping Center—Bradford Woods
Martinsville, Indiana
Department of Recreation and Park Administration, School of HPER

Endorsed by the National Therapeutic Recreation Society
a branch of the National Recreation and Park Association



"PERMISSION TO REPRODUCE THIS
MATERIAL IN MICROFICHE ONLY
HAS BEEN GRANTED BY

Gary M. Robb

TO THE EDUCATIONAL RESOURCES
INFORMATION CENTER (ERIC)."

U.S. DEPARTMENT OF EDUCATION
NATIONAL INSTITUTE OF EDUCATION
EDUCATIONAL RESOURCES INFORMATION
CENTER (ERIC)

This document has been reproduced as
received from the person or organization
originating it.

Minor changes have been made to improve
reproduction quality.

• Points of view or opinions stated in this docu-
ment do not necessarily represent official NIE
position or policy.

ERIC
Full Text Provided by ERIC
R 14090



Contents

Page

BRAD, WOODY AND ROSE: THE IEP IN THE OUTDOOR ENVIRONMENT—AN INSERVICE APPROACH Marcia Jean Carter, Re.D. Thomas Hussman Lisa Master Claudia Mey Paula Webber	I
<hr/>	
THOSE THAT DO CAN ALSO TEACH: SHARING YOUR EXPERIENCE WITH OTHERS Jeffrey P. Witman	7
<hr/>	
SUPPLEMENT YOUR PROGRAM EVALUATION—TRY OBSERVER SYSTEMS! Christopher C. Roland	11
<hr/>	
THE WILDERNESS EXPERIENCE: A COST EFFECTIVE TREATMENT MODALITY FOR PSYCHIATRIC PATIENTS Daniel D. Ferguson	22
<hr/>	
HOLISTIC PROGRAMMING AT E.C.H.O. Frank Robinson	31
<hr/>	
THE VALUE OF HETEROGENEOUS GROUPINGS FOR THE PERSONAL GROWTH WILDERNESS ADVENTURE Thomas E. Smith	40
<hr/>	
CIRCUIT TRAINING: TOTAL PHYSICAL FITNESS FOR PERSONS WITH DISABILITIES Dale E. Abell	52
<hr/>	
RISK TAKING AS AN EDUCATIONAL TOOL Marda Gilmore Bureau	63
<hr/>	
UTILIZING HERITAGE ARTS WITHIN OUTDOOR EDUCATION EXPERIENCES Karen Schultz Jan Beaman	68

A NEW WAY OF LOOKING AT ORIENTEERING 81
Thomas E. Barham

REMOVING BARRIERS TO THE BARRIERS: 95
A NEW ADAPTED ROPES COURSE
Kirk B. Weaver

ACCESS RECREATION—DESIGNS AND PLANS 108
Silas P. Singh, Ph.D.

OUTDOOR EDUCATION AND CAMPING CONFERENCE 115
COORDINATION: A COORDINATOR'S PERSPECTIVE
Christine Sopczynski

Forward

Innovative programs that are based in the natural environment provide an excellent rationale for coping with contemporary concerns about educational effectiveness and alternative learning environments. For professionals that have been involved in outdoor based programs and for individuals with disabilities who have had opportunities to participate in such programs, the above statement is not a new revelation. However, there remains a significant segment of our "professional culture" that has either not considered the possibilities that outdoor programs can offer or has yet to be convinced of their value in education and rehabilitation.

The *Bradford Papers* is a collection of selected articles that reflect innovative efforts to not only bring exciting outdoor based programs to persons with disabilities, but also to provide a chronicle that can be used in demonstrating the potential and effectiveness in the educational and rehabilitation processes. This Volume is the third in a continuing series of papers that have been printed as a result of the Annual Institute on Innovations in Camping and Outdoor Education With Persons Who are Disabled. This National Institute is held each May at the Bradford Woods Outdoor Education, Recreation, and Camping Center in Martinsville, Indiana.

Volume III consists of twelve articles that address the areas of leadership training, innovative program approaches and area-equipment-facility accessibility. In addition, we have elected to provide the readers with some insight into the planning and development of the Institute in the final article. These articles represent a broad array of philosophies and approaches and are reflective of many years of experience and research by the respective authors. Readers are encouraged to utilize the information contained in these pages to add new dimensions to their own programs and as a basis for convincing others of the value of camping and outdoor education.

Gary M. Robb
Editor

BRAD, WOODY, AND ROSE: THE IEP IN THE OUTDOOR ENVIRONMENT - AN INSERVICE APPROACH

CONTRIBUTORS: MARCIA JEAN CARTER, RE. D.
THOMAS HUSSMAN, LISA MASTER,
CLAUDIA MAY, PAMELA WEBER
BRADFORD WOODS
MARTINSVILLE, INDIANA

Special education over the past 25 years has experienced rapid growth. Since the passage of PL 94-142 in 1975, the education of all handicapped children has received further attention and impetus. Yet, professionals concerned with providing appropriate learning environments and experiences have expressed difficulty in meeting the individual needs of students.

The natural environment offers one alternative to an individualized holistic setting for acquiring knowledges and skills necessary to function as independently as is possible. Education in the out-of-doors is a methodology for facilitation the individual growth and development of all participants. Regardless of the particular functioning level, the therapeutic-outdoor specialist is able to identify through activity analysis appropriate experiences for enabling the accomplishment of behaviors defined in the students' Individualized Education Plan (I.E.P.) statements. Additionally, and more importantly, the specialist is able to use the outdoor environment as a training environment for the special educator who is the primary link to the home and community of the special participant.

Project TORCH, funded from 1977 to 1981 by the Office of Special Education, was intended to develop competency based inservice training for teachers and other professionals working with special participants in the outdoor environment. The primary activities of the project were transferred from Camp Allen in New Hampshire to Bradford Woods in Martinsville, Indiana where additional funds were received from the state to continue the training of special educators while developing the outdoor environment as an alternative learning experience. The objectives for the teacher inservice training programs at Bradford Woods are presented as:

1. To identify procedures for using the outdoor environment as a means to implement the IEP objectives for handicapped children and youth.
2. To expose special education teachers to an outdoor experience so they feel comfortable in planning and leading these outdoor activities with their students.

- 3. To introduce a variety of activities, i.e., nature, creative arts, adventure recreation, etc., and identify procedures for effective presentation, utilization, and evaluation of the experience with the students.
- 4. To expose teachers to a "hands-on" learning method that utilizes the natural environment in either the classroom or in an outdoor setting.
- 5. To provide an opportunity for the teachers to become aware of the resources available in outdoor education for persons with disabilities.

Major apprehension on the part of the participating teachers was concerned with their unfamiliarity with the outdoor environment and the realization that the residential outdoor experience demands involvement in all phases of living and learning for at least a 24 hour period. Thus, the inservice training session was envisioned as a simulation for the actual teacher-student residential experience. The session therefore required the teachers to "role play" experiences as their students might participate in as well as to become comfortable with the primary transmitters of the learning concepts in the outdoor environment. To accomplish these ends, the inservice training was designed to involve the teachers in didactic learning activities, student assessments,

and evaluations, and to make the experience as realistic as possible with respect to the functioning levels of their students.

To achieve this last goal, the trainers created three fictitious characters as representative of generic functioning levels; Bradford, represented a high functioning student who experienced difficulty with abstract concepts, fine motor coordination, large group interaction skills and expression of subtle emotions. Rose, assumed the intermediate functioning level with noted delays in cognitive skills, motor performance, social behavior, and emotional involvements. Woody, became the reference for lower functioning students who experience noticeable multiple decreases in all behavioral areas, cognitive, affective, sensory-motor, and social. These three characters became the reference point for teacher identification of abilities representative of their own students. Further, these characters became the reference for modifying and adapting the training activities to enable the realization of individual student objectives appropriate to the educational plans for each student. In essence, "Brad", "Rose", and "Woody" became the trainers' students to facilitate the teachers' understanding of selecting and modifying outdoor learning experiences appropriate for the possible functioning levels of students participating in the Bradford Woods outdoor education programs.



The outdoor experiences selected for the teacher training were determined to represent educational curriculum areas. These areas were defined as pre-academic such as matching and identification; academic or cognitive like following directions and sorting; motor, both gross and fine; communication, both verbal and nonverbal; social interaction; sensory awareness; and ADL or activities of daily living such as dressing, toileting, feeding. Activities were selected which allowed for the display of behaviors from each of these areas. Through the activity analysis process, activity objectives were placed into three levels with an objective appropriate to each of the three characters developed for as many of the curriculum areas as was possible. Two of the introductory activities are presented to illustrate the manner in which this information was shared with the teachers.

Activity: Name Tags

Individual Education Plan (IEP) Objectives:

1. Woody will recognize his name (cognitive, pre-academic)
2. Rose will print her name independently with at least two different natural items (fine motor, academic)
3. Brad will print his name independently with at least four different natural items (fine motor, academic)

Description: This activity promotes awareness of the natural environment and provides a means of learning names. Each participant is instructed to use natural objects to spell out his name. Instruction and supervision must be given to prevent the students from

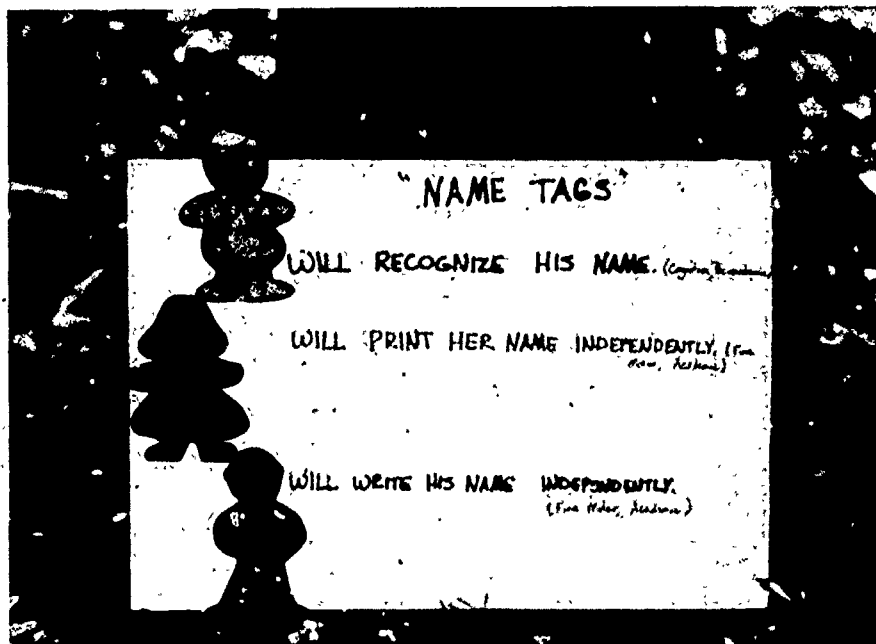

"Woody, Rose, Brad"

picking live objects. The natural objects can be applied with glue, tape, etc., to a variety of materials, i.e., paper, cardboard, clay, sandpaper, or placed in sand filled boxes. After completing the names, the students can discuss questions like why they chose their specific natural objects, how many objects they chose, and what they liked about the activity. This activity provides a fun way for the students to learn their own and each others names.

Activity: Nature Guess Who?

IEP Objectives:

1. Woody will answer yes and no questions (communication)
2. Rose will follow game rules (social, cognitive)
3. Brad will use descriptors (adjectives and adverbs) in communicating ideas or questions (communication)

Description: This activity not only helps to "break the ice" but stimulates the children to be aware of nature concepts, objects, and other people. Form a circle facing toward the center. Tape or pin either a picture of a nature object or the name of the object on the back of each child so that he does not know the object portrayed on his own back. Each child has a different object. The children mingle and ask only yes or no questions to

determine "what" or "who" they are. Questions like, am I red? Am I a living thing? Am I heavy? Am I an animal? Or am I a person? can be asked. When a child has successfully guessed what he is, he can put his object on the front of his shirt and continue to help others. The activity ends when all children have guessed correctly. A discussion can follow to allow the students to express their feelings.

All activities in which the teachers participated were presented in this fashion. The "hands on" material served to aid the teachers in their transfer of classroom objectives to the outdoor environment. Additionally, the written descriptions aided their understanding of each student's ability to acquire different skills while participating in the same activity.

The inservice training program was sequenced so that the teachers would become familiar with the Bradford Woods facility while becoming acclimatized to a number of alternative learning experiences appropriate to the functioning levels of their students. The trainers exposed the teachers to each learning site or area via a tour presented by "Brad", "Rose", and "Woody". At each station, figures representing the three characters identified appropriate objectives for each of the

three levels for activities appropriate to the particular program area. When the teachers reached each station, the trainers introduced and lead the teachers in the activities according to the possible functioning levels. A debriefing followed each activity. The trainers and teachers discussed how each character represented their specific student's and modifications necessary to enable the achievement of the students' IEPs. Two of the activities conducted while on the tour are presented with the objectives identified for Bradford, Rose, and Woody.

Activity: Color Search

IEP Objectives:

Brad

1. Will read color words (cognitive)
2. Will match color patterns and color word sequences (pre-academic)

Rose

1. Will independently match 10 colors (academic, pre-academic)
2. Will work independently 15-20 minutes (pre-academic, social)

Woody

1. Match three colors with minimal assistance (pre-academic, motor)
2. Follow directions (social, communication)

Description: Each student is handed a small sack or envelope containing strips of certain colors. They are instructed to find natural objects of the same colors. Instruction must be given so that the students do not pick plants, flowers, or harm trees. This can be played competitively or as a group initiative. During times when not many colors are available in the natural environment, pieces of colored paper may be placed in a given area. The students match the colors. If colored paper is used, be sure to clean up the paper when finished.

Activity: Animal Tracks

IEP Objectives:

Brad

1. Independently follow sequential directions (cognitive, communication)
2. Increase reading/library skills (using books about animal) (academic)

Rose

1. Increase fine motor dexterity (motor)
2. Make decisions when faced with choices (cognitive, social)

Woody

1. Learn body parts (feet, etc.) (communication, cognitive)
2. Increase use of palmar grasp (fine motor)

Description: After finding and identifying a track, children pour a plaster of paris mixture into the track. When this has dried, the molds are removed from the soil, and lightly brushed off using an old toothbrush. An adaptation to this activity is to use boxes of damp soil and by hand form various tracks, followed by pouring the plaster of paris mixture into the boxes and allowing the mold to dry.

Following the tour, the teachers developed a program for their students selecting the activities most appropriate to the IEP statements previously prepared for their students' classroom experiences. General program areas included creative arts, nature, aquatics, adventure recreation, outdoor living skills, cabin activities, and special events. The student residential experience extended from two nights and three days to four nights and five days. During this time period, the teachers were expected to assess their students' experiences as related to the achievement of their IEPs. This was planned for by requesting the teachers to evaluate their inservice experience considering both the administration and leadership of the experience as well as their understanding and use of the outdoor environment as a resource for the acquisition of student behaviors in the identified curriculum areas.

Documentation and follow-up communication with the trainees have provided evidence for the transfer of the outdoor education experiences to the home and community of participating teachers and students. Further, results of the inservice training have extended beyond leadership training to concomitant effects on the training and involvement of teachers, administrators, families and students. As quoted from one teacher, "There is a lake near our school which I never knew I could use with my students." One administrator reported on a follow-up questionnaire, "I believe our children could learn more if they spent nine months outdoors and three months in the classroom." Because the outdoor environment is a "natural", an invitation is extended to each student and teacher to seek out, create, test, adapt, explore, see, hear, feel, taste and touch using personal assets and native abilities. Teachers and students learn by doing, motivators and reinforcers are built into the learning process. Regardless of the functioning level, the concept of "Brad", "Rose", and "Woody" can be transferred from the outdoor environment to the classroom IEP.

THOSE THAT DO CAN TEACH:

SHARING YOUR EXPERIENCE WITH OTHERS

JEFFREY P. WITMAN
UNIVERSITY OF NEW HAMPSHIRE
DURHAM, NEW HAMPSHIRE

Eric Hoffer (1977) has compared a "learned" with a "learning" society. The former is characterized by a rigid set of facts or truths which are mastered and applied throughout a lifetime. In contrast the "learning" society is one characterized by change, one in which knowledge has a half-life and in which professionals who stop learning will literally stop working. Our American society, especially in regard to relatively new fields such as outdoor education, seems to clearly be a "learning" one. Changed social, political, economic and scientific realities are the norm and they demand that professionals develop new competencies to cope with them.

Continuing education is a must. To allow education to take the bulk of the responsibility for developing and implementing continuing education opportunities in outdoor programming is to disregard the answers to some critical questions regarding continuing education needs. Who for example, best knows the answers to the following questions:

- What do consumers want and in what ways are consumers changing?
- What new practices or innovations work and what are their limitations?

- What are the strengths and weaknesses of fellow professionals?
- To what extent is outdoor programming gaining credence from administrators, other professions, parents, or the general public?

Seemingly, each of the above questions can best be answered by doers, practitioners actively involved in providing outdoor programming with individuals having disabilities. Collectively they can avoid the all too common mistakes of traditional approaches to continuing education—didactic instruction, lack of respect for the experiential base of participants and the assumption that one miraculous intervention (film, workshop, learning activity) can achieve instant change and growth.

The sections which follow are designed to serve as food for a thoughtful critique of current practices in training and continuing education. Consider your current involvements as you review perspectives on quality practices and future needs.

QUALITY PRACTICES

Assessment of needs is a critical starting point for the development of continuing education opportunities. Assessment should include not only the "wants" of

potential participants but also their needs as determined by their clients, peers and supervisors.

Planning for continuing education needs to be equally broad-based including the input of all those effected by programs. Individual learning styles and preferences for types of learning activities (e.g., role plays, brainstorming) need to be accomodated. Walsh (1981) has added the critical consideration of a problem orientation in continuing education. Client service data-satisfaction with programs, safety records in programs, achievement and growth through programs-being viewed as the basis for determining problems to be addressed in continuing education.

In implementing continuing education programs it's important to remember that conventional forms of teaching strategy (lectures, focus on content, emotional distance between teachers and learners) are not ideally suited to most adults (Hutson, 1980). The anxiety and resistance inherent in confronting new ideas and change requires an emphasis on the processing of learning activities. Sharing concerns and discussing misgivings and doubts are critical prerequisites to accepting new perspectives. Additionally support and encouragement throughout a learning experience is vital. Techniques of support can include:

-aiding with realistic goal setting and aiming for multiple outcomes in case some don't materialize.

-aiding with recognition of the important ways in which new competencies can be applied.

-using learners' prior performance as the standard for evaluating progress, and

-having learners assist with teaching and support of others.

The evaluation of continuing education programs needs to move beyond the extent to which the food was enjoyed. Kress (1980) has identified a chain of evaluative criteria beyond the commonly employed level of opinion or happiness scales. These include:

1. knowledge/attitude data- the extent to which new competencies and/or beliefs have developed.
2. clinical process measures- the extent to which practices have changed.
3. patient-impact measures- the extent to which clients are better served.

Kinsey (1981) adds the dimension of social impact assessment. Improvements in public understanding of outdoor programming, enhanced linkage with other professions, and strengthened involvements with our own professional societies are examples of measures of the social impact of continuing education efforts.

Formative evaluation designed toward improved future efforts is critical as well. Formative measure:

should provide insight regarding why experiences were successful as well as why experiences failed. Exclusive dependence upon formative measures however, can give credence to the poignant critique of Friedrich (1980):

"One of the concerns I have about getting too caught up in evaluation techniques is that very often evaluation degenerates into thinking about only doing things right. This constantly allows you to do what you are doing better, but does not allow you to open yourself to asking, "Are we doing the right things?"

FUTURE SCENARIO

Outdoor programming with individuals with disabilities has experienced a period of phenomenal growth in recent years. It has truly been a period of "more"-people, programs, materials, equipment. Governmental belt tightening coupled with the ascendance of a "back to basics" philosophy threaten this growth. Participants* in the 1982 Institute on Innovations in Camping and Outdoor Education with Persons Who Are Disabled were asked several questions regarding the theme of keeping outdoor programming alive and growing:

* -N=20

1. Who Is Most Important To Reach? (# of times listed as priority in parentheses)**

Parents/Consumers (35)
Administrators (28)
Political Leaders (28)
Teachers (21)
General Public (18)

Others: Churches (3), Foundations (2), Rich and Famous Private Citizens (e.g., Ed Asner), College Student Leaders, Voluntary Agencies, Handicapped Advocacy Groups.

2. What Is Most Important For Them To Become Competent? (# of times listed as priority in parentheses)**

Philosophy/Rationale (24)
Objectives/Evaluation (22)
Activities/Evaluation (18)
Administration/Resource (14)

Others: Emotional Involvement/Commitment (2), Program Benefits, Volunteering.

3. How Can They Most Effectively Be Reached? (# of times listed as priority in parentheses)**

Demonstrations With Students/Clients (30)
Public Information Campaigns/Awareness Materials (26)
Workshops/Conferences (21)
Books/Articles/Curr. (6)

Others: Assist/Observe In Programs (4).

**participants prioritized each of the categories vs. each other category and also added their thoughts on "other" important categories.

A FINAL THOUGHT

Quality continuing education can provide a secure floor and an open ceiling to the advancement of outdoor programming and the skills of those who lead it. A secure floor in the sense of remedial and corrective perspectives—insuring personal and collective foundations of confidence and competence. An open ceiling in the sense of developmental and expansive perspectives—serving as a catalyst for personal and collective openness to continual growth.

Additional quality continuing education affords the opportunity for outreach, for enlisting new supporters of outdoor programming with disabled individuals. If only two hundred current advocates were each to reach twenty new "believers" each year for the next five years a total of twenty thousand new advocates would be available to the fight for expanded and improved programs. The inevitable result would be a higher percentage of individual with disabilities involved in and benefitting from the dynamic medium of outdoor programming.

Continuing education and training are expensive endeavors. Let's make them count for something!

REFERENCES

- Friedrich, G., "Training As An Intervention In The System," in K. Byers (ed.) LEARNING FROM OUR PRACTICE...PLANNING OUR FUTURE DIRECTIONS, Bloomington, Ind.: National Inservice Network, Indiana University, 1980.
- Hoffer, E., IN OUR TIME, New York: Harper & Row, 1977.
- Hutson, H., INSERVICE BEST PRACTICES: THE LEARNING OF GENERAL EDUCATION, Bloomington, Ind.: National Inservice Network, Indiana University, 1979.
- Kinsey, D. C., "Participatory Evaluation," ADULT EDUCATION, 31:3, 155-168, 1981.
- Kress, G. C., "Continuing Education: Does It Effect The Practice Of Dentistry," in P. M. Cunningham (Ed.) YEARBOOK OF ADULT AND CONTINUING EDUCATION, 1979-80, Chicago, Ill.: Marquis Academic Media, 1979.
- Walsh, P. L., "A Model for Planning Continuing Education For Impact," JOURNAL OF ALLIED HEALTH, 101-106, May, 1981.

SUPPLEMENT YOUR PROGRAM EVALUATION-TRY OBSERVER SYSTEMS!

DR. CHRISTOPHER C. ROLAND
HANCOCK, NEW HAMPSHIRE

Educators and recreators are often searching for new methods to initiate or supplement their program evaluation. Unfortunately, they are often limited by time, money, expertise and enthusiasm, with an end result being a less than adequate evaluation design.

During the past few years, innovative evaluation methods known as observer systems have begun to be implemented in a variety of programs. Included are education programs (Cheffers 1977; Dougherty 1970; Furst 1971) recreation programs (Roland & Witman 1982), outdoor education programs for business executives (Roland 1981) and outdoor education programs for special populations (Cheffers 1979). These observer systems are generating much excitement across this wide range of programming. However, they need to be described and explained carefully if their true potential is to be realized.

Observer systems are tools to study "dynamic, on-going interaction between people" (Simon & Boyer 1967). They allow an observer to use a coding system in order to divide behaviors (leaders' and participants') into meaningful and manageable categories. The observer can then record the particular behavior and analyze the resulting data to some method of data analysis.

Common forms of observer systems include anecdotal recording (Cartwright & Cartwright 1974), dialogue analysis (Hughes 1962), and participant observation (Cheffers 1977). During the last decade two reliable observer systems have been developed that generate (1) detailed information concerning interaction between a leader and participants (CAFIAS) and (2) participant involvement (I.R.G. II). Both instruments will be reviewed in the following pages.

CAFIAS

The Cheffers' Adaptation of the Flanders Interaction Analysis System (CAFIAS) is predominantly a process system designed to describe verbal and nonverbal behaviors in teaching and modifying human interaction. This is attained by recording moment by moment behaviors during interaction.

CAFIAS was developed by Dr. John T. F. Cheffers of Boston University with an initial emphasis on coding physical education teachers. Adapted from the original Flanders Interaction Analysis System (FIAS), CAFIAS has been developed into a strong instrument that emphasizes the recording of verbal and nonverbal interaction. The need for the inclusion of nonverbal behaviors in the description of teacher/student interactions has been well documented

(Galloway, 1970; Gibb, 1960; Jenkins, 1961; Mitzel & Rabinowitz, 1953; Smith, 1959). Additionally, CAFIAS allows an observer to record whether the students are learning from the teacher, the other students, the environment (video presentations, field trips, etc.) or a combination of teacher-student-environment. The use of these "teaching agents" seems to be a critical link to adult learning (Cheffers, 1980).

Figure 1 shows both the verbal and nonverbal behaviors that are coded for the trainer and trainee.

A trained observer codes the interaction between trainer and trainee every three seconds or whenever there is a change in behavior. Thus, in a twenty minute period of coding, approximately 400 codes would be tallied. Verbal interaction is recorded using single numbers: 2, 3, 4, 5, 6, 7, for the trainer and 8, 8', 9, for the trainee. Nonverbal interaction is recorded using the 'teen' equivalent of the single digits: 12, 13, 14, 15, 16, 17, for the trainer and 18, 18', 19, for the trainee. When there is verbal and nonverbal interaction occurring simultaneously, the number for the verbal behavior is circled (e.g., ④).

COMPUTERIZATION OF CAFIAS

Upon completion of the coding period(s), all codes are then transformed into computer codes. CAFIAS was originally a FORTRAN program, and then modified in the programming language PF/I. Transformation

of 800 codes, typing of the codes into the computer, and running the program takes approximately two to three hours. CAFIAS can be obtained as punched card decks or on magnetic tapes.

Once a program is run, an analyst interprets the data that offers a leader some valuable feedback. Percentages are given that include:

- how often the leader talked
- how often the leader used nonverbal communication
- the leader's total contribution
- how often the students talked
- how often the students used nonverbal communication
- the students' total communication
- how often silence and confusion occurred
- the amount of class time the leader devoted to subject matter (content cross)
- the amount of class time during which the trainer was the teaching agency
- the amount of time during which the environment was the teaching agency
- the amount of time during which one or more students were the teaching agency

Specific information can also be obtained that includes how often the trainer used praise, acceptance, questions, lecture, criticism and how often the students gave expected, narrow responses or broad interpretive responses or creative responses. This computer data is typically transferred to a graph for a succinct illustration/interpretation. Figure 2 is an example of such a graph.

FIGURE 1

CATEGORIES FOR INTERACTION ANALYSIS

TEACHER TALK	INDIRECT INFLUENCE	<p>*1. ACKNOWLEDGES FEELINGS: Clarifying or dealing with the feeling tone of the students in a nonthreatening manner. Feelings may be positive or negative. Predicting or recalling feelings is included.</p> <p>*2. PRAISES OR ENCOURAGES: Praising or encouraging student action or behavior. Jokes that release tension, but not at the expense of another individual; nodding head, or saying "um hm?" or "go on" and statements of confirmation such as "That's right" are included.</p> <p>*3. USES IDEAS OF STUDENTS: Clarifying, building on, summarizing, developing or repeating exactly the ideas suggested by a student. As teacher brings his/her own ideas into play, shift to Category 5.</p> <p>*4. ASKS QUESTIONS: Asking a question about content or procedure with the intent that a student answer.</p>
	DIRECT INFLUENCE	<p>*5. LECTURES OR ORIENTS: Giving facts or opinions about content or procedures; expressing his/her own ideas, asking rhetorical questions.</p> <p>*6. GIVES DIRECTIONS: Giving directions, commands, or orders with which a student is expected to comply.</p> <p>*7. CRITICIZES OR JUSTIFIES AUTHORITY: Statements intended to changes student behavior from nonacceptable to acceptable pattern. Bawling someone out. Using the fact that one is the teacher to justify a point or to counteract student response.</p>

CATEGORIES FOR INTERACTION ANALYSIS (cont.)

**STUDENT
TALK**

- *3. **STUDENT TALK-LIMITED:** A student makes a predictable response to teacher. Teacher initiates the contact or solicits student statement and sets limits to what the student says.
- *9. **STUDENT TALK-UNLIMITED OR INITIATED:** Open-ended or unpredictable statements in response to teacher. Talk by students, which they initiate. Shift from 8 to 0 as student introduces own ideas.
-

- *10. **SILENCE OR CONFUSION:** Pauses, short periods of silence, and periods of confusion in which communication can not be understood by the observer.
-

*There is NO scale implied by these numbers. Each number is classificatory; it designates a particular kind of communication event. To write these numbers down during observation is to enumerate--not to judge a position on a scale.

Figure 2

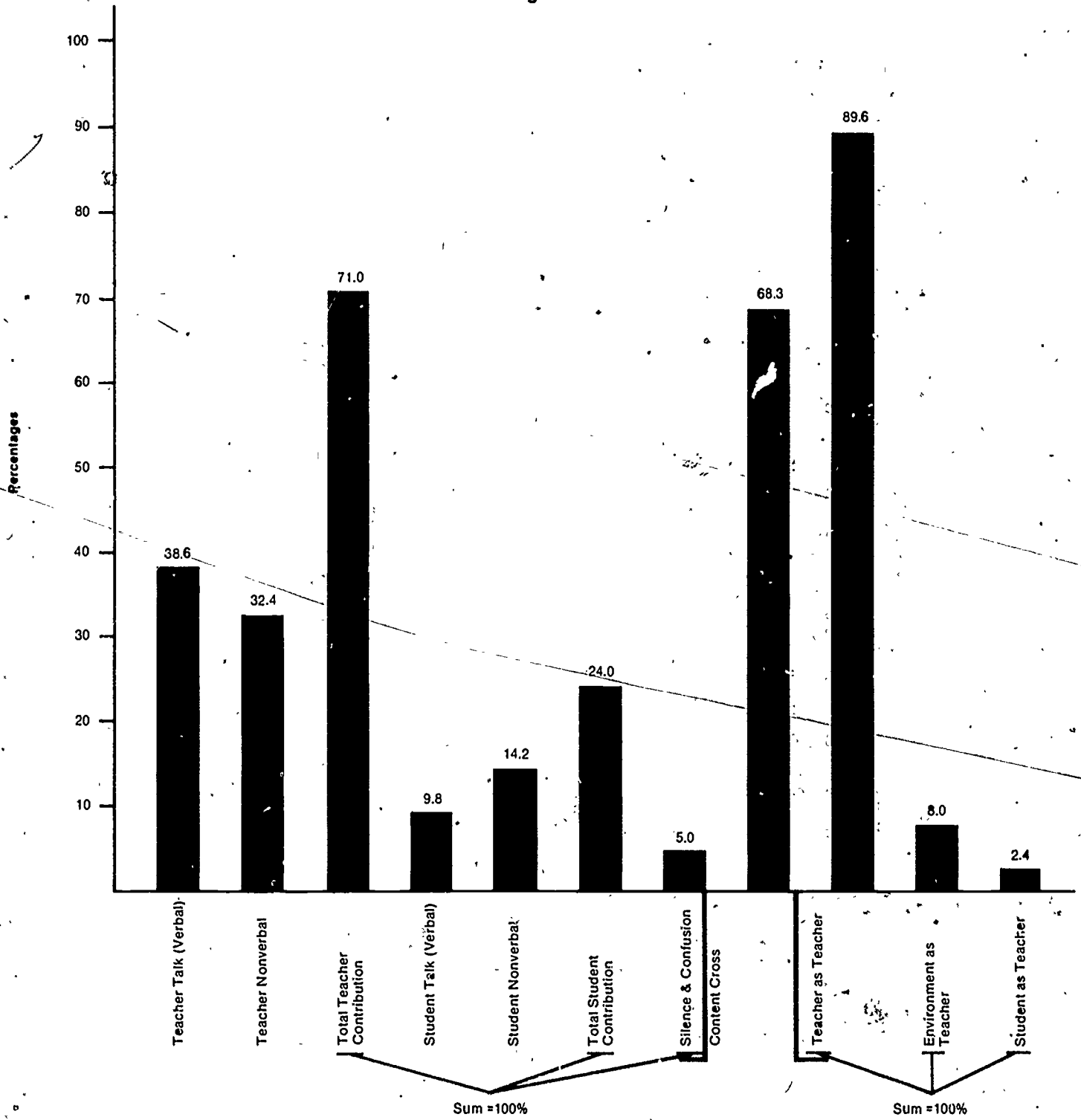

Interpretation of this graph (Figure 2) includes:

1. The majority of class time (71%) was spent with the leader communicating. Of this time, he was more verbal than nonverbal.
2. Student contribution was 24%.
3. A minimum of silence and confusion occurred.
4. His instruction content was 68.3%.
5. The leader was the main teaching agency (89.6%), with some use of the environment (chalkboard) (8.0%) and students as the teacher (2.4%).

Additional information not obtained on this graph included:

- the leader asked questions (5% verbal, 4% nonverbal)
- when the students interacted with the leader, he acknowledged their ideas or gave praise 2% of the time
- students showed initiative (7% verbal, 3% nonverbal)

This information, which should be shared with the leaders, can help:

- determine staff consistency
- pinpoint common weaknesses (lack of nonverbal communication too little participant response, etc.)
- single out specific activities that demonstrate high percentages of leader acceptance of ideas, acceptance of feelings, and praise-areas that are important to learning (Cheffers, 1980; Wood, 1978).

I.R.G. II

A reliable instrument that measures individual and group involvement is Individual Response Gestalt (I.R.G. II). As Cheffers, Brunelle and Von Kelsh (1979) stated, "The question of involvement is critical to human functioning. The degree to which people commit their attention, interest and labor determines the ultimate success of the venture at hand"

I.R.G. II was developed out of five years of research at Boston University; it is simple in structure, discrete in categorizations and easy to subscript and postscript. Validation and computerization procedures are continuing at the University's School of Education.

I.R.G. II is comprised of six behavioral categories which illustrate a continuum of intensity of a person's involvement—from no involvement to intense and out-of-control emotional involvement. These categories are shown in Figure 3.

The essential procedures for administering this instrument are as follows:

1. Verbal behaviors of individuals are coded with numerals one through six (1-6), which correspond with relevant behaviors.
2. Nonverbal behaviors are coded in the same classifications by utilizing the "teen" equivalent (eleven through sixteen).

FIGURE 3

INDIVIDUAL REACTION GESTALT (IRG) II

A Description Thermometer Measuring the Involvement of an Individual Set Against the Gestalt of the Total Group Or Overall Group Involvement

CATEGORIES

V NV 1 11	V NV 2 12	V NV 3 13	V NV 4 14	V NV 5 15	V NV 6 16
No Apparent Involvement	Distracted	Spasmodic Involvement	Engrossed Involvement	Emotionally Involved	Ultimate Involvement
ILLUSTRATIVE BEHAVIORS					
Wandering around the institution or learning area usually occupied doing something else not at all task oriented.	Present, but not giving the lesson concentration. Asleep, or talking with someone.	No permanent focus. Fluctuates concentration on and off task.	No apparent emotional release. Leaning forward, eyes never leaving the task.	Strong emotion. Laughing, smiling, frowning, but emotions and reactions are in control.	Strong, excessive emotional release. Reaction to task on environment is not under control.
CONCEPTS					
LOW INVOLVEMENT		SPASMODIC	INTENSE INVOLVEMENT		

Suggested Subscripts: V: Violence
 N: Negative-connotations
 G: With group or another individual

3. When the verbal categories are circled, an individual is expressing verbal and nonverbal behaviors simultaneously.
4. The subscript "N" after a category number indicates that an observed individual is behaving in a negative or hostile manner.
5. A further subscript "V", recorded instead of an "N", indicated that the participant is not only acting negatively, but with signs of physical, or verbal, violence as well.
6. A postscript "G" is used when the participant is interacting with other individuals.

The coder records the appropriate behaviors every ten (10) seconds, or whenever there is a change in behavior. Codings are recorded on a horizontal flow chart, developed by Crowley (1980). (Figure 4)

This instrument can help school and camp program directors, coordinators, teachers and counselors determine those activities that generate the highest levels of involvement. As importantly, decisions can be made as to modifications of activities that generate lower levels of involvement. Thus, I.R.G. II can help document (or denounce) the age-old statement. "Oh yes--the kids really get involved with that activity lesson."

TRAINING

Schools, camps and outdoor education centers can train their staffs in the use of these instruments in a short period of time. In order to establish coder reliability (and hence program evaluation reliability) individuals should be trained and checked on acceptable inter-coder reliability by an established coder. Please contact the author for information on available CAFIAS and I.R.G. II coders.

Today we face an incessant high tide of escalating program costs; participant recruitment difficulties, and tightening budgets. As a result, we are faced with the task of substantively evaluating our programs. To merely say, "this program works" is no longer an acceptable evaluation. We must strive to enhance our evaluation systems; with tools such as CAFIAS and I.R.G. II we are on the right track. But we cannot stop here--we must continue--continue to be innovative in this cryptic area we call evaluation.

FIGURE 4

IRG II SWEEP SHEET

(Developed by Eileen M. Crowley)

MINUTE NUMBER:
 CATEGORY: 1 2 3 4 5 6 7 8 9 10 TOTALS:

	1	2	3	4	5	6	7	8	9	10	TOTALS:
1											1=
2											2=
3											3=
4											4=
5											5=
6											6=

COMMENTS: TOTALS:

MINUTE NUMBER:

	1	2	3	4	5	6	7	8	9	10	TOTALS:
1											1=
2											2=
3											3=
4											4=
5											5=
6											6=

COMMENTS: TOTALS:

INVOLVEMENT PERCENTAGES:

EMOTIONAL INVOLVEMENT: Categories 5+6 =
 $\frac{\text{Grant Total of categories 5+6}}{\text{Grand Total}}$
 PRODUCTIVE INVOLVEMENT: Categories 4+5+6 =
 $\frac{\text{Grant Total of categories 4+5+6}}{\text{Grand Total}}$
 COGNITIVE INVOLVEMENT: Category 4 =
 $\frac{\text{Grant Total of category 4}}{\text{Grand Total}}$
 ULTIMATE INVOLVEMENT: Category 6 =
 $\frac{\text{Grant Total of category 6}}{\text{Grand Total}}$

REFERENCES

- Cartwright, C. & G. Cartwright, DEVELOPING OBSERVATIONAL SKILLS, New York: McGraw-Hill, 1974.
- Cheffers, J., "Independent Evaluation of A Four Day Residential Outdoor Education Program," Unpublished Manuscript, Boston University.
- Cheffers, J., V. Mancini & T. Martinek, INTERACTION ANALYSIS: AN APPLICATION TO NONVERBAL ACTIVITY, St. Paul, Minn.: Paul S. Amidon and Associates, Inc., 1980.
- Cheffers, J., "Observing Teaching Systematically," QUEST, 28, 17-28, 1977.
- Crowley, E., "I.R.G. II Sweep Sheet," Unpublished Document, Boston University, 1980.
- Dougherty, N., "A Plan for the Analysis of Teacher-Pupil Interaction in Physical Education Classes," QUEST, 15, 39, 1970.
- Furst, N., "The Multiple Languages of the Classroom: A Further Analysis and Synthesis of Meanings Communicated in High School Teaching," Unpublished Doctoral Dissertation, Temple University, 1967.
- Galloway, C., "Nonverbal, the Language of Sensitivity," THEORY INTO PRACTICE, 10, 227-230, 1971.
- Gibb, J., "Socio Psychological Processes of Group Instruction," DYNAMICS OF INSTRUCTIONAL GROUPS, (Fifty-ninth yearbook of the National Society for the Study of Education, Part II) Chicago, Illinois: University Chicago Press, 1960.
- Hughes, M., "What is Teaching? One Viewpoint," EDUCATIONAL LEADERSHIP, 19, 251-259, 1962.
- Jenkins, D., "Prediction in Interpersonal Communication," JOURNAL OF COMMUNICATION, 11, 129-235; 166, 1961.
- Mitzel, H. & W. Rabinowotz, "Assessing Socio-Emotional Climate in the Classroom by Withall's Technique," PSYCHOLOGICAL MONOGRAPHS, 67, 1-19, 1953.
- Roland, C., "The Transfer of an Outdoor Managerial Training Program to the Work Place," Unpublished Doctoral Dissertation, Boston University, 1981.
- Roland, C. & J. Witman, "Issues in Assessment of Outdoor Programming With Special Populations," ASSESSMENT FOR THE 80's... TAKING STOCK, Poultney, Vt.: Journal Press, 1982.

Simon, A. & G. Boyer,
"MIRRORS FOR BEHAVIOR,"
Philadelphia: Research
for Better Schools, 1967.

Smith, H., "The Teacher
and the World of
Language," COLLEGE
ENGLISH, 20, 172-178,
1959.

Wood, D., "Adventure-Education
Through Participant
Observation and Interaction
Analysis," Unpublished
Doctoral Dissertation,
Boston University, 1978.

THE WILDERNESS EXPERIENCE: A COST EFFECTIVE TREATMENT MODALITY FOR PSYCHIATRIC PATIENTS

DANIEL D. FERGUSON
MICHIGAN STATE UNIVERSITY
EAST LANSING, MICHIGAN

Many articles have appeared in the literature describing the therapeutic benefits of any number of camping programs for those with mental and emotional disturbances (Byers, 1979). It is the intent of this author to describe and examine the cost effectiveness of a four day wilderness camping experience for adult patients from an acute treatment unit of a state psychiatric hospital.

The wilderness camp setting has been discussed in numerous articles as a particularly good environment for the treatment of those with emotional disturbances. Research in this area of camping has been largely inconclusive, but even so the advantages of this kind of programming still seem to be numerous. Among them are freedom from artificiality and "harsh coercion", opportunities for nonrestrictive creative experience (McNeil, 1957); the influence of the group experience (Goodrich, 1974; Hobbs and Shelton, 1972); and a developed sense of personal responsibility and discipline (Loughmiller, 1965).

Over a three year period, several short term camping programs were conducted at Eastern Oregon Hospital and Training Center which is located in the foothills of the

Blue Mountains of Northeast Oregon. The excursions varied in length and program emphasis, but marked behavior changes were noted in a number of participants after each excursion. Since there were no medication changes or drug holidays for those who attended these programs, it was felt that the behavior must have somehow been a result of social or environmental factors directly connected to the camping experience.

Without a systematic approach to examining these issues, it is impossible to know or fully comprehend the reasons for such drastic behavior changes as occurred. It is likely, however, that an important factor was simply the change in social environment from a rather sterile institutional setting with clearly defined social roles and few demands for personal responsibility and discipline to less comfortable more intensive social living experience in a micro-community with no clearly defined social roles and high expectations as far as a personal responsibility.

The change in physical environment may also have had a strong influence at behavior. The design on Eastern Oregon Hospital and Training Center is dependent upon a very hard architectural style. (Sommer, 1974) consisting of concrete walls, tile floors and heavy institutional furniture laid out in configurations which foster isolation rather than promote socialization. The environment on the camp outings was a wooded setting with a central camp and a campfire which helped draw people together for informal activities such as singing and card playing.

Other factors affecting behavior may have been the increased opportunity for one-to-one counseling from staff, the structured group activities in which participants* were involved, the symbiotic relationship between the individual and the group with each depending on the other for personal comfort and safety, or the positive feedback individuals received for jobs well done in cooking one pot meals for the group or other such chores. There may also have been an increased feeling of "normalcy" created by a less clearly defined therapist/participant relationship which contributed to the ability and willingness of participants to examine and modify their behavior. It is

also likely that some modeling of staff behavior occurred since it was possible for participants to observe the staff in a continual living experience for a few days rather than on an 8 a.m. to 5 p.m. basis.

In the treatment of psychiatric patients, there continues to be a good deal of unknown information. The use of antipsychotic drugs, and other chemical treatments is standard yet not everything is known as to how these chemicals work. The exact benefits or processes involved in group therapy are not fully understood, but they too are standard practices in psychiatric facilities. What is known about these treatment modalities, is that they are effective in helping to treat individuals with mental illness and they are cost effective in that they help to reduce the length of hospitalization required by most people. At a time when the economic circumstances surrounding many psychiatric programs are suffering, it is worth examining the cost effectiveness of recreational activities which are not fully understood, but which seem to have a significant effect upon behavior to see if they can actually help to reduce the length of hospitalization and by so doing decrease the actual cost of care.

*Editors Note: the word "participants" has been substituted for "patients" throughout this article.

Below is a description and cost analysis of one such program.

PROGRAM DESCRIPTION

The adults were involved in a four day backpacking trip into the rugged Wenaha-Tucannon Wilderness Area which encompasses several thousand acres of land in Oregon and Washington. This particular wilderness area is much less well known than the other wilderness areas of these states, presumably because it is somewhat isolated and has fewer outstanding features. The reputation of the Wenah-Tucannon stems from its very steep and rugged trail system as well as its scenic beauty. It is a popular area for a few elk hunters who utilize horses to carry in their supplies.

Five hospital staff accompanied the group including two recreation therapists, a student intern in Therapeutic Recreation, the Director of Social Services, and a medication aid. Each staff member had first aid CPR training, as well as backpacking experience.

The participant group consisted of seven males and two females with a variety of diagnoses. Two were diagnosed as schizophrenic, one had a character disorder, two were alcoholics, one was a poly-substance abuser, and four suffered from acute situational depression. Only two of the ten participants had been hospitalized for an extended period. The rest had been in the hospital one week to ten days.

The selection process for the trip was a treatment team effort. Participants were selected from three acute treatment wards by the treatment teams of each ward with advisement from their recreation therapist. The selection for criteria were: 1) they should be well enough (i.e., not actively psychotic, not suicidal) to benefit from the trip without being a liability to the staff involved or the overall safety of the group; 2) they should not have any physical limitations or conditions which would cause them to be a liability or detract from the safety of the group; and 3) that they not be in the process of having discharge plans made and preparing to leave the hospital. The trip was not included as part of the comprehensive treatment plan of any of the participants since it was not an ongoing recreational activity, but individual objectives for each person were developed by the recreation staff. These were documented in each participant's record prior to the camp experience, and a follow up note was made upon return.

A few days before the trip, the participants were involved in some pre-trip activities which were used to purposefully teach outdoor skills and heighten enthusiasm for the backpack experience. Pre-trip activities included the making of tin can stoves, fire starting devices and plastic rain covers for the hikers and their backpacks. They also learned how to set

up their tents. A topographical map of the 16 mile route was reviewed and a discussion of proper clothing selection, footwear and safety procedures followed. The evening before the trip, participants learned how to pack their packs and all of the food and equipment for the group was equitably divided. There was no formal attempt to increase the fitness level of the group, but some were involved in an ongoing fitness program.

Early the day of departure the equipment was loaded into vehicles, and with great anticipation the group departed for the mountains and the wilderness area. The hiking for that day centered on a seven mile section of trail which progressed steeply downward to the bottom of a canyon where the group crossed and followed the Imnaha River to the first campsite location, where foil dinners provided a new adventure in outdoor cooking for most. The evening was spent relaxing, contemplating the tiring hike of that day and enjoying the beauty of the outdoors.

The second day saw a very stiff group from the downward hike of the afternoon before. Camp was broken after lunch and a relatively short hike of a few miles helped to get the kinks out. When camp was pitched again the enthusiasm of the group was still high, but signs of fatigue were beginning to show.

The morning and part of the afternoon of the third day were spent in structured group activities which included learning about photography, panning for gold, participating in a blind trust walk and a group problem solving exercise called, "Lost At Sea." The purpose of the activities was to help participants see the potential value of certain hobby skills, to help them learn to trust others or utilize them as a resource when necessary, as well as to help increase the meaning and value of being out-of-doors and experiencing the environment more fully.

Late in the day, camp was again broken and the party moved up the trail along the Imnaha River. When camp was pitched this time, there was little enthusiasm left in the group. The physical and mental limits were being tested, but socially the group was performing very well. Those assigned certain tasks continued to fulfill them and strong comradery had developed.

The final day found the group breaking camp for the last time and preparing for a five mile walk up out of the canyon to a trailhead where they would be picked up. There was a sense of renewed vigor as people thought about what lie ahead. When all had reached the end of the trail, there was tremendous sense of accomplishment expressed. For several of the participants it was the most challenging

activity, or group experience they had ever been involved in. For others, it brought back memories of things they had done for several years. And now they could look back on the experience with satisfaction, joy and laughter.

A few days after the trip, a follow up activity was held so that slides from the trip could be shown and awards given to each participant. It was obvious then that several of the participants in this activity had made marked improvement in their behaviors with the only explainable cause for change being the wilderness experience. Less than a week later, four of the ten who participated in the trip were discharged from the hospital.

FOUR INDIVIDUAL CASES

JOHN

John was a male in his mid-thirties who had been admitted seven times in two years for alcoholism. On a few of his previous admissions, he had eloped from the facility and never followed through on his discharge plans. He was admitted for the eighth time in June of 1981 a few days prior to the trip. He was told that he had a penetrating ulcer, and that continued drinking would eventually cause the ulcer to penetrate the stomach and he might possibly die. John seemed to take this matter seriously.

The trip brought back many memories to John. He talked of similar trips and hunting trips with his father. He shared his outdoor skills with others and was very helpful in accepting responsibility for chores. Upon return to the hospital, he began immediately working with his team for discharge. He got a job and in a day or two was discharged giving credit for this to the backpacking trip. John had not been readmitted to the hospital since.

LORI

Lori was a young, heavy set woman in her mid-twenties. She had been admitted to the hospital for depression and suicide attempt. She had never been backpacking before, but thought it sounded like an adventure. The second day on the trail she got a severe cramp in her calf. With difficulty she was able to make the required distance that day, and her leg was massaged and draped with hot towels. Her leg remained sore and on the last day of hiking, a staff member volunteered to carry her pack the last two miles to which she snapped, "I've carried this thing this far, and I'll make it all the way!" With that she hurried on up the rest of the trail.

The trip had definitely helped her depression lift and by her own admission she had been challenged to her physical limit. As soon as plans could be made, she was discharged and has not been readmitted.

PEGGY

Peggy was a woman about age 33 who had been admitted with a combination of problems resulting from alcohol abuse, depression and a suicide gesture. Prior to the trip, she had been somewhat manipulative and controlling of other participants. She had done some backpacking and was able to convince Lori and Jan that if she was going on the trip that they should too.

The first day of hiking, Peggy was anxious to "do her stuff" for her friends. But by the third day her attention was focused on benefitting the group. She had also given considerable thought to how she would deal with some of the problems that caused her to become hospitalized and as soon as appropriate plans were made, she was discharged and has not returned to the hospital.

JAN

Jan was a 28 year old woman who was married with two children. She lived in a logging community of thirty-five families. Her husband, who was a logger, had been laid off four months earlier, and they had been having marital problems since that time. Jan began developing a number of fears and phobias until one day she became so frightened she ran her car off the road; narrowly escaping serious injury. Among her fears were a fear of heights and a fear that a tree might fall on her.

On the trip neither of these fears seemed apparent even though most of the time was spent in deep forest, and there were many places that the trail was only several inches wide and overlooked an almost vertical embankment. In requesting to be discharged, she was asked by her psychiatrist what made her feel she was ready to return home. She related that while on the camping trip she was forced to face most of the things she was so afraid of and that with the support of the group, she was able to overcome her fears in a controlled setting. Now she was ready to try and face her fears in the community. She was subsequently discharged and did not return to the hospital.

COST EFFECTIVENESS OF THE TRIP

The actual cost effectiveness of this wilderness experience is impossible to measure as there were so many variables involved. But the following figures help to illustrate that this type of programming may actually contribute to a significant savings in overall treatment costs.

Consider first of all the cost of treating a single participant in a psychiatric facility. The daily cost of treatment on a per participant basis at Eastern Oregon Hospital is \$115. The average length of stay in the Acute Treatment Unit is seventeen days. This means the average cost of treating one participant would be \$1,955.

Assuming that the four people mentioned above were average participants, it might have been predicted upon their admission that they would be hospitalized for seventeen days. But after their wilderness experience, each of the participants was quickly discharged, shortening their stay to approximately twelve days each. This is five days short of the average length of stay, and would mean a per participant cost savings of \$575 or total savings of \$2,300.

But what was the cost of the trip? In order for this program to have been at all cost effective the expenditures for the wilderness trip need to be less than the total cost savings to participants. The actual cost figures for the trip indicate that such was the case. (Figure 1)

Using these figures it is clearly seen that there was a significant cost savings based on the assumption that the four participants who were discharged would have been hospitalized for the average seventeen day period. There may have been an additional savings as well since the patient John did not return to the hospital after a history of several admissions.

On the surface, one would have to say that in terms of dollars and cents, this wilderness camping program not only benefitted the participants, but helped to significantly reduce the cost of treating four of them.

But before this evidence could be considered conclusive more investigative work would need to be accomplished in order to determine if any of the other six participants were hospitalized for a longer period of time than they would have been otherwise due to their wilderness experience. Work would also need to be done to determine whether the length of hospitalization of the four participants discussed was any shorter than for other participants with the same diagnosis since the seventeen day average stay is based on a general figure for all participants regardless of diagnosis. The effect of this program type should also be compared with other activities such as leisure counseling or other less intensive out trips.

SUMMARY

As the emphasis on quality assurance and the search for third party payments continues, it will become increasingly important for recreation therapists to demonstrate not only the effectiveness of their programs, but also the cost/benefit ration. This paper is intended to present a superficial glance at the cost effectiveness of one wilderness camping experience with a limited number of acute psychiatric participants. Further investigation with more detail is needed to further support the evidence presented here.

FIGURE 1.

TRIP COST FIGURESActual Trip Costs

Gas for 2 vehicles	\$ 72.00
Copying & Promotion	1.50
Film & Developing	21.00
Collect Phone Calls	1.80
Miscellaneous & Food	35.00

(Most of the food taken was requested from the hospital kitchen)

\$131.30 SUBTOTAL

Treatment Savings	\$2,300.00
Actual Trip Cost	- 131.30
Cost Savings	<u>\$2,168.70</u>

Hidden Costs

Staff Salaries for four days

a. 2 Recreation Therapists	\$ 690
b. Director of Social Service	440
c. Student Intern	80
d. Medication Aid	240

\$1,450 SUBTOTAL

Treatment Savings	\$2,300.00
Actual & Hidden Costs	-1,581.30
Cost Savings	<u>\$ 718.70</u>

REFERENCES

- Byers, S. E., "Wilderness
Camping as a Therapy
for Emotionally Disturbed
Children: A Critical
Review," EXCEPTIONAL
CHILDREN, 628-634, 1979.
- Goodrich, L., "Unregimented
Camps for Problem Children,"
In T. P. Lowry (Ed.),
CAMPING THERAPY: ITS
USES IN PSYCHIATRY AND
REHABILITATION," Springfield,
Illinois: Charles C.
Thomas, 1974.
- Hobbs, T. R. & Shelton, G. C.,
"Therapeutic Camping for
Emotionally Disturbed
Adolescents," HOSPITAL
AND COMMUNITY PSYCHIATRY,
23, 298-301, 1972.
- Loughmiller, C., WILDERNESS
ROAD, Austin, Texas:
The Hogg Foundation for
Mental Health, University
of Texas, 1965.
- McNeil, E. B., "The Background
of Therapeutic Camping,"
JOURNAL OF SOCIAL ISSUES,
13, 3-14, 1957.
- Sommer, R., TIGHT SPACES:
HARD ARCHITECTURE AND
HOW TO HUMANIZE IT,
Englewood Cliffs, New
Jersey: Prentice Hall,
1974.

HOLISTIC PROGRAMMING AT E.C.H.O.

FRANK ROBINSON
NORTHEASTERN UNIVERSITY
BOSTON, MASSACHUSETTS

Picture this scenario--a rather large, rugged and bearded male figure is explaining "The Warm Fuzzy" story to a group of severely disabled and non-disabled children in a shady setting while a more graceful feminine figure pantomimes the story. The audience is enraptured with the adventures of happy little people who long ago dwelt in the little village of Swabeedo and went about with broad smiles and cheery greetings for everybody.

One of the things the Swabeedoo-dahs liked best was to give Warm Fuzzies (little furry balls) to one another. Each of these little people carried over his shoulder a bag, and the bag was filled with Warm Fuzzies. Whenever two Swabeedoo-dahs would meet, each would give the other a Warm Fuzzy. Now, it is an especially nice thing to give someone a Warm Fuzzy. It tells the person they are special. It is a way of saying, "I like you". And of course, it is pleasing to have someone give you a Warm Fuzzy. When you have a Warm Fuzzy held out to you, when

you take it and feel its warmth and fuzziness against your cheek, and place it gently and lovingly in your fuzzy-bag with all the others, it's just extra-nice. You feel noticed and appreciated when someone gives you a Warm Fuzzy, and you want to do something nice for them in return.¹ The lives of the Swabeedoo-dahs were happy together until---the cold prickly people invaded---

The story goes on and, like the excitable adventures of E. T., it holds the group intently. At the end everyone is told to form small groups and to close their eyes. Each is given a Warm Fuzzy. Then, the Fuzzies are exchanged and in turn each person expresses to the other something special they like about them.

The "Warm Fuzzy" story has tremendous impact on both campers and counselors. It opens up a healthy exchange of communications, promotes self-esteem and helps us all to give and receive more freely. The Swabeedoo-dahs and Fuzzies become a bond, an "in-secret" between E.C.H.O. people.

E.C.H.O. (Environmental Camp for Handicapped and Others) in Goshen, Massachusetts is the place of the scenario. The figures are Recreation and Leisure Studies students and faculty from Northeastern University in Boston, Massachusetts. The "warm fuzzy" story is just one activity of the holistic program at E.C.H.O.

Each morning after breakfast, flag-raising and before announcements, campers and counselors participate together in Sunshine Therapy. The leader may be the Director, Nurse, student counselor or a combination of leaders. Sunshine Therapy is a combination of activities in which all campers and staff participate. Children in wheelchairs are lowered to the ground and everyone finds a comfortable space around the flagpole. Relaxation and stretching exercises are taught and practiced initially. When most people think of "relaxation", pleasurable activities such as hobbies, vacations, reading or watching television usually come to mind. While these relaxing diversions can be valuable and enjoyable energy outlets, they acutally do little to ease residual tensions and rarely offer the body a complete rest. A scientific definition of relaxation involves the complete absence of neuromuscular activity and includes the deepest kind of rest. This type of relaxation is a learned skill which can be developed

through the practice of specially designed relaxation techniques. This learned skill can be particularly helpful to children with tight muscles such as those with Cerebral Palsy. Progressive relaxation, differential relaxation, relaxation of body parts and other techniques are practices by everyone.

A guided imagery session with eyes closed may follow the exercises:

"and now as your body relaxes and quiets down, let your mind become quiet also. Imagine that your mind is serene, silent and peaceful, slowing down to a soothing slow pace ...and as your mind is at ease, we will go quietly into our minds to a place where we feel completely safe and secure. This can be a place you already know about, perhaps your room at home, a tree house, or it can be a place you build in your mind, but wherever it is, go there now and arrange it exactly the way you want it, to make you feel safe, secure and "at peace."

Pause a minute...

"And now that you have found your special place, you can go there whenever you want. You can go there to think, to be yourself even if you are with others, to

feel good no matter where you are. Now let's return to the present, knowing that our special place will be there when you want it."

Imagery, the seeing of pictures in the mind, is crucial to education. For children with severe physical limitations it is particularly important. It facilitates developing the creativity of the mind, it is necessary for remembering, for visualizing associations and it enhances self-esteem. Through imagery you can take children in wheelchairs hiking up a mountain, exploring a cave or setting the stage for an adventure that they can complete by writing about "what happens next".

Sunshine therapy usually concludes with everyone finding a partner for the purpose of expressing love and nurturance through touch. Little children spontaneously reach out to express and to receive physical affection. Many of us learned though, that after a certain age such touching was not considered appropriate. Hence, it is not surprising that we and our children often have our need for physical contact met in a roundabout manner. We sit and stroke our pets. We play contact sports such as football and pile on top of one another. We make love when we need only some holding. We get sick sometimes so that we can then be touched and stroked,

None of these practices allows us to experience and receive as much nurturance as we could be receiving if we were more open about our needs.²

An example of a touch exercise would be Back-of-Neck-Caring. Givers are asked to take away all of the tension in the back of their seated partners neck concentrating on the back and sides of the neck only. The leader explains the muscle involved and the stroking techniques.

Receivers are asked to close their eyes, to sit quietly, enjoy the massage and to think about what they would like to say to express thanks to the giver. After ten minutes or so, everyone changes roles--though it is not necessary to do this on a strictly reciprocal basis. The head, face, shoulders, hands, back and feet are the anatomical parts massaged during these sessions. A genuine caring and sharing environment is created and supported. We encourage the children to give their very best to their partners and then switch and relax so they can receive and accept nurturance. It is heart-warming to see the enjoyment expressed on the face of a young girl with arthrogryposis, and little use of her hands, as she adaptively tries to relieve tension from her counselor's neck muscles. This is an open giving and receiving atmosphere. Frequently disabled children believe they are incapable of giving

or making someone else happy. In Sunshine therapy they oper'y do this.

If people in our environment reflect back to us that we are unworthy, not fully capable, not unique or essential we begin to believe this and to create complimentary belief systems. How can we possibly love ourselves? If, on the other hand, people in the environment reflect back to us our unique beauty, our lovability, our capability, our essential nature, how can we not learn to love ourselves?

At the heart of holistic thought is the person in his totality, the whole person: mental, physical, emotional, social and spiritual. The basic overriding theme of holism is a genuine respect and acceptance of each person as a unique human being. All people, regardless of ability or disability, are valuable as people and each has an inherent capacity for growth and development. This is important!! Staff must truly believe this in order to function for a common purpose. This is why it is essential to have careful staff screening and an extensive training program to share the holistic philosophy and develop community building. The staff are seen as role models, therefore it's important that they exemplify the holistic philosophy, and offer support and nurturance to each other. Remember, to make a successful program we must practice what we preach.

The holistic philosophy embraces the idea that all human beings are of unconditional self-worth and value without regard to behavior or physical and mental disorder. The disabled individual needs to strengthen self-esteem and it is necessary to meet his accentuated needs. Building and reinforcing self-esteem at every opportunity is vital.

Examples of programs which enhance self-concept at E.C.H.O. are activities such as the Camp Pledge, Individualized Camper Awards, and the E.C.H.O. tree.

At the welcoming campfire ceremony, each camper and counselor is asked to make a pledge of something they can do during camp that will contribute to the overall experience. Some elect to do something every day such as gather firewood for campfires, decorate the dinner table with flowers, tell a joke or place a riddle on the riddle tree. Others are more ambitious pledging to paint the flagpole or to write camp songs. The pledge is a method for recognizing that everyone has the ability to contribute. It encourages independence, creativity and develops a sense of self by helping the individual to determine what he can do and then to either do it himself or seek help. Names and pledges are displayed on the wall of the recreation room for all to see.

At the final banquet, individualized and personalized awards are given to each camper in recognition of their unique personality and the contributions they made to the E.C.H.O. family. The awards ceremony is a way of saying "Thanks" for happy times at camp. Campers show great appreciation of the awards and many display each one, year after year, in their rooms. Camper awards symbolize achievement and represent the unique personal self or identity that campers portrayed to their camp friends.

The E.C.H.O. Tree is a replanted pine that is so designated. The idea developed from feeling that the final morning of camp each session was too much one of sad partings. It was believed that some kind of joining together for a purpose and giving a gift remembrance may help to reduce the tears and sadness and turn the last day of camp more into a day of joy and gladness.

At opening campfire, secret pals are selected out of a hat and each person is instructed to make something for that person from items found around camp. These "homemade" articles are then placed under the E.C.H.O. tree after breakfast on the final day of camp. Counselors may help with the gift making for those too severely handicapped to do it themselves, but the campers ideas and input

are required. A program of songs, picture taking and laughter enhance the giving and receiving of gifts. Great appreciation is shown for the effort involved in making a gift which, to the unknowing, appears worthless and insignificant. The E.C.H.O. Tree is a way of expressing love and caring and showing that whatever a person can do is accepted and appreciated.

The holistic concept contains several other elements beyond the belief in each person's dignity as a human being. It is also concerned with the individual's interrelationships with other people. This element of program is fostered at E.C.H.O. by its overall structure of severely disabled children participating and living with their non-disabled friends. The social integration of children at a buddy camp such as E.C.H.O. is less stressful than mainstreaming and therefore more therapeutic to all concerned.

VALUES OF INTEGRATED CAMPING

THE DISABLED CHILD

- *is exposed to the give and take of real life
- *is given a chance to compete and to cooperate in a safe environment with able-bodied peers

*is given constant feedback on his acceptance, adjustment and ability to "measure up" socially in a reality situation

*is provided motivation to become more independent in ADL skills

*is provided opportunities to gain recognition from non-handicapped individuals and groups

*is afforded greater opportunities to strengthen self-esteem through satisfactions gained through meeting individual needs and demonstrating abilities and inner qualities to the larger group

*is frequently in a position to teach the non-disabled about his disability and related problems

*is in a position to develop friendship with non-disabled peers

THE ABLE BODIED CHILD

*is exposed to children with varying disabilities

*is educated about disabilities and comes to grips with personal attitudes and feelings toward them

*is afforded a unique learning experience by being able to see "first hand" what individuals with limitations can do

*is confronted with the opportunity to develop insight into one's own personal self and inner feelings about health, talents and life in general

*is exposed to health related career fields which may have an impact and can later be pursued

*is in an environment where caring, sharing, humility, patience and other humanistic qualities can be learned by helping people in need and giving of oneself

*is provided the opportunity to befriend a person who is disabled

Trust activities such as the "trust fall," "trust circle" or "trust walk," the friendship stick ceremony, traditional camp activities, sharing a tent with one's buddy, and community integration all enhance the building of positive relationships with other people.

The holistic concept also concerns itself with the relationship of the individual to the universe and the "mysteries of life." Spiritual services at camp, confronting such issues as values of life purpose and sensory and environmental awareness are all effective programs designed to bring the camper to a closer relationship to the world around him.

The holistic model used at E.C.H.O. is derived from two major sources: 1) The work of Robert Assagioli, an Italian psychiatrist who created a theory of human development and integration known as psychosynthesis; and 2) the work of Paula Klimék and Jack Canfield who have developed a new model of Education--a master's degree program in Holistic Education--distilled from their understanding and experience with psychosynthesis and humanistic and transpersonal education. My colleague

Sandra Skelly had the good fortune of studying under the guidance of Paula Klimék for the past two years. Sandy's extensive nursing background and her training and work in psychosynthesis, my many years of experience and understanding of the handicapped child, and our combined efforts at effectively demonstrating holistic principles at E.C.H.O. have synthesized into the following model.

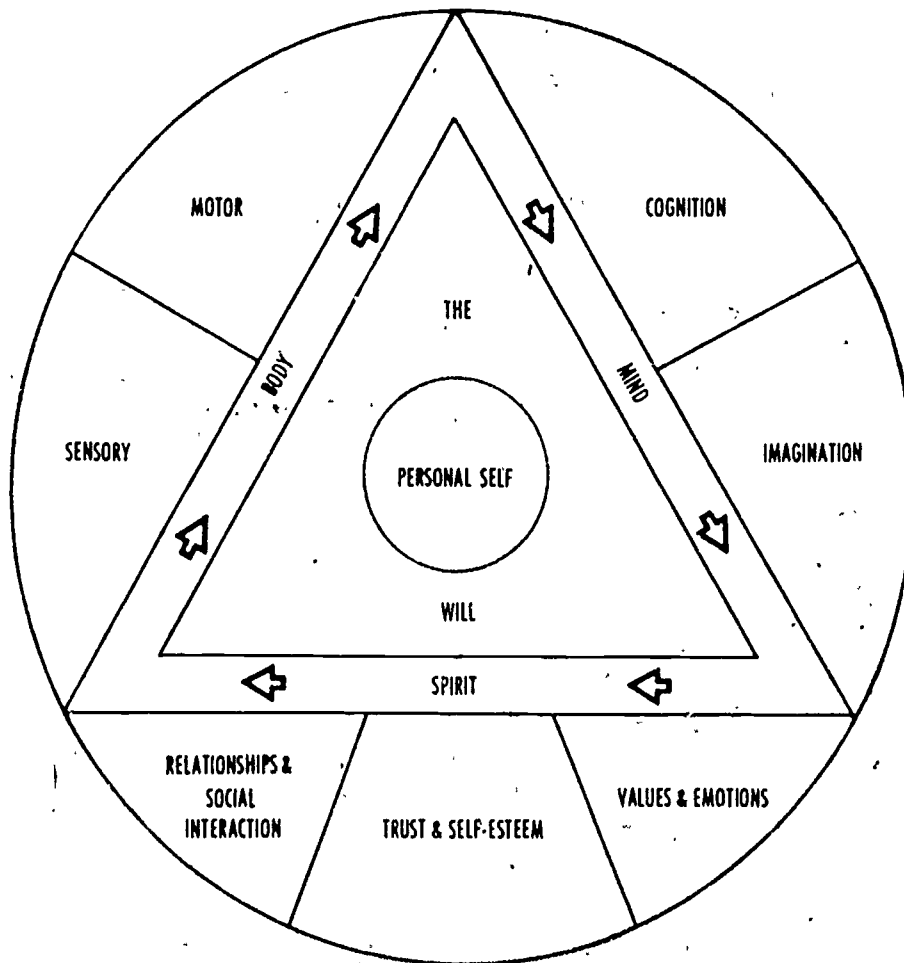

HOLISTIC MODEL IN CAMPING AND RECREATION
FOR THE DISABLED CHILD

The holistic model is an attempt to represent visually what we have done at E.C.H.O. and what it means to be a whole human being. The model will change and expand with human evolution and the discoveries of man's potential, however, a brief description of our interpretation follows.

The "personal self" is the unifying center around which the integration of each dimension of the person takes place. It enables the individual to perceive clearly that which is occurring in the environment. "The Will," used in all areas of life, is the ability to choose and act upon awareness in one's life. The "body, mind and spirit" represents the three dimensions of mankind. The triangle is not fixed, but viewed as a revolving unit which integrates with the programmatic components of the individual. These are perceived as sensory/motor, cognition/imagination, relationships and social interaction, trust and self-esteem, and values and emotions.

The holistic model applies to all people yet it is found to be particularly applicable to the disabled child in an integrated environment setting. Societal norms, values, attitudes and prejudices prevent the handicapped child from expressing his "whole self." He is often defined as a child with a disabled body and a disabled mind having limitations. The holistic model affirms that we all have resources

and potentials far greater than what we use in day to day living. As Kevin, a quadriplegic cerebral-palsied young teenager in a Mulholland chair, has expressed in his journal to the question, "What do you think about the activities conducted at E.C.H.O.?", "They give me a feeling of being unlocked and free to do things I never dreamed were possible. They are fun! They make me feel good about myself!"

Holistic activities draw upon the child's inner resources and strengths. They emphasize ability, minimize disability, seek potential in both, promote self-esteem and self-love, encourage risk-taking and the expression of personal attributes. The activities have been tried and tested. They work!

When considering the whole person it is important to remember that the activities used will relate to more than one dimension of the personal self. It is very difficult to compartmentalize activities. Just as the body, mind and spirit are separate yet interrelated, so also are the expressive dimensions of the individual.

A text entitled, "A Holistic Perspective on the Disabled Child: Applications in Camping, Recreation and Community Life" will be published in late Winter of 1983 by Charles C. Thomas Publishing Co., Springfield, Illinois. Holistic concepts and principles are fully discussed in this book documented by contemporary case studies and ongoing programs.

END NOTES

1. Richard Lessor, Fuzzies, Argus, Niles, Illinois, 1971.
2. Paula Klimek, "Befriending our Children", New Age, December, 1979, p. 43.

REFERENCES

- Assagioli, Roberto. Psychosynthesis. Penguin Book Co., N. Y., 1965.
- Assagioli, Roberto. The Act of Will. Viking Press, New York, 1973.
- Canfield, Jack and Paula Klimek. "Education in the New Age," New Age. February, 1978.
- Canfield, Jack and Harold Wells. 100 Ways to Enhance Self-Concept in the Classrooms. Englewood Cliffs, N. J., 1975.
- Klimek, Paula with Jack Canfield. Guided Fantasy: Application in the Classroom. New England Center, Amherst, 1978.
- Klimek, Paula. "Befriending our Children", New Age. December, 1979.
- Lessor, Richard. Fuzzies. Argus, Niles, Illinois, 1971.
- Simon, Sidney. Caring, Feeling, Touching. Argus Communication, Niles, Illinois, 1976.
- "Wilderness Beyond...Wilderness Within..." A collection of papers by Dr. Tom Smith, Psychologist/Wilderness Guide.

THE VALUE OF HETEROGENEOUS GROUPINGS FOR THE PERSONAL GROWTH WILDERNESS ADVENTURE

THOMAS E. SMITH, PH. D.
BEHAVIOR. EDUCATION CENTER
WHEELING, ILLINOIS

The typical "wilderness adventure trip," be it backpacking, canoeing, winter camping, caving, climbing, or whatever, can be organized and designed with a number of different underlying motivations. Some trips are offered as recreational, with the essential goal of relaxation, excitement, and vacation. Other trips set the primary goal as enrichment of each participant's understanding of the natural environment and the delicate balance between the human species and the planet earth. Still other trips are offered to teach basic "survival skills," and to pit modern man's individual resources against the elements of nature. There are many subthemes for adventure groups, including weight loss or conditioning, nature photography, family therapy, certification or coursework in outdoor education, and anthropological/archaeological study of more primitive civilizations.

Still, the most often cited motivation for the wilderness trip is that of "personal growth." Even when the primary motivation for an outing is enhancement of the psychoecological awareness of participants, or weight loss, or essentially recreational, there is very

often a parallel goal of guiding the individual toward a better understanding of self, others, the environment, the self-other interdependency, the self-environment interdependency, and the subsequent improved adjustment in the total spectrum of life. It is this very potential for the outdoor adventure trip to stimulate the individual and the group towards a healthier, more humanistic, more optimistic, higher order of human-being-ness which has brought overlap between wilderness adventure and education, psychotherapy, rehabilitation, and re-adjustment counseling. It is this overlap between the "wilderness beyond" and the "wilderness within" which has brought this author to the occupational titling of "psychologist/wilderness guide".

It is an awareness of the potential personal growth impact of the outdoor adventure that has brought me to explore the application of therapeutic growth exercises to the outdoor environment, and to seek out special knowledge of sun exercises and tribal rituals from the native American Indians for adaptation to the present day adventure trip. In appreciation for the balance between the

outdoors and the indoors,
I have started a number of
personal growth workshops
and special adventure
journies with the following
words:

"So you want to learn?
To grow? To understand?
To know? Then do not
run wildly through the
trails of life.
Slow down. Come to Center.
Breathe deeply. Sense
the colors of the world
around you. Hear the
sounds of the environment.
Reach down and touch
the Earth. Reach up
and draw forth the
energy of the Sun.
Look, even better, stare,
At all the little
things in the world,
At all the big things
in the world, At all
the living things of
the world, And at all
the dying things of the
world. As your eyes
fill, rest them in
closure, But keep on
looking, inward, deep
at your Center...
That is where the
wisdom is to be found.

Over the past twenty
years I have guided/facilitated
more than two hundred
groups on adventure trips
that ranged from a few days
to a few weeks. Each group,
each special journey, was
unique. Often we camped,
sometimes we climbed and
rapelled, sometimes we
explored wild caves, and
almost always we have canoed
in the boundary waters area
of Minnesota. We have also
climbed boulders or rest
stop walls along the roadside,

tubed on highwater country
creeks, toured the Wisconsin
Cheese Factories, picniced
in small town and big city
parks, worked through teams
courses and high ropes,
challenges, sunstretched
on the lakeshores, chanted
harmoniously in old farm
silos, and spent nights on a
giant tarp in a "group
sleep" under the stars.

HETEROGENEOUS VS. HOMOGENEOUS ADVENTURE GROUPS

The central thesis of
this paper is simply that
there is much value in the
adventure group being
"heterogeneous." While I
have guided/facilitated
groups that were essentially
"homogeneous," including
teenage delinquents,
married couples, college
students, special education
students of either "retarded"
or "emotionally disturbed"
classification, and businessmen,
my personal remembrances
are that more good happened
for more of the participants
when the group was more
"heterogeneous." I have
worked with groups that
included children below five
and adults beyond seventy-five,
some participants who were
blind or handicapped and some
who were quite able-bodied.
I have included combinations
of mother and son, youth
workers and their clients,
college students and troubled
youth. I have had delinquent
teenagers, retarded adults,
vacationing teachers, and
some of my own six children,
all on the same adventure trip.
People have so very much to
give to one another.



"...there is much value in the adventure group being 'heterogeneous'".

The typical adventure group numbers 10-12 participants, and a couple of leaders. With a range of attitude, behavior, expectancy, interest, capability, and skills---and the unfolding dynamics of a building tribal bond---everything is possible. People take care of people. The group designs its' own flow to accomodate all the members and there is truely an experience of sharing, caring, and working together to accomplish the tasks at hand. To my knowledge, most of the organized and implemented outdoor adventure programs operate with essentially homogeneous groups. Programs are often offered by contract or

assignment from a special population school, a half-way house or rehabilitation program, a college class, or some county or state correctional institution. Field stations concentrate on special contacts with the retarded or disabled, or offer special trips for "teenagers" or "women only." All too often, there is little thought given to the possibilities of broadscale heterogeneous groupings. An initial reaction to the idea is often, "impossible." It would appear that the habit trend has been set, and part of basic promotion of the adventure group trip involves definition of the particular characteristics of the group to be served.

My argument for heterogeneous groups for the wilderness adventure is considerably subjective to date, as there has not been any significant empirical data collected on the validity of the concept. (It is worthy to note that there really has not been much adequate research on the process and outcome of the whole adventure group experience, and important sub-variables such as group size, length of program, and homogeneous vs. heterogeneous groups, certainly warrant closer empirical study.) There is, however, some related theory, discussion, study, argument, and support for my hypothesis of greater value in heterogeneous groups on the adventure/growth journey.

TRENDS FROM SPECIAL EDUCATION

Anyone familiar with the whole field of special education knows that the historic developments were heavily influenced by categorization and segregation. Special classes and programs for the "retarded," "physically handicapped," "learning disabled," and the "emotionally disturbed" or "behavior disordered," have developed, in part, from two basic arguments. First, it was argued that there was merit in homogeneous groupings for instruction and behavior management purposes. The argument was simply that we could do better for these children by putting them into common denominator piles.

The second argument was that there was value in categorization and segregation of special children in that it protected them from dealing with the ridicule and rejection that their differences brought. Some would argue that there was a third reason for the special programs being isolated, segregated, and homogeneously caged; namely, the mainstream educational programs avoided the difficulty of blending a handicapped child into their world. This latter argument would, of course, be most often denied by professional educators, and they would quickly defend their practices by advocating arguments one and two above...."it's better for them." In any case, a network of homogeneous groupings of students with similar problems, parallel instructional needs, and comparable adaptive skills has evolved.

There were, of course, always that minority who argued against the unfolding special education empire of homogeneous/segregated classes/programs, but the field grew expansively into the seventies. Then, the impactful Public Law 94-142, overseeing all of special education, and making the important recommendation for providing each child with the "least restrictive alternative," came to be. Basically, the law pointed up that it was each child's right to have the special programming needed, and that that programming should be offered in the educational

setting that was least removed from the mainstream and afforded maximal opportunity for interaction with all other children. The law does not say that some children do not need separate, segregated, intensified classes---it simply says that some children do not need that, and are entitled to a less restrictive placement.

There has been much argument and challenge to P. L. 94-142. The nations schools have been mandated to move away from some of the more traditional homogeneous and segregated programs when possible, and towards more heterogeneous interaction between handicapped and non-handicapped children. There have been many lessons to learn, for both the special educators and their students and for teachers and students of the mainstream. Direct experience for the regular schools of dealing with the physically handicapped, the mentally retarded, or the emotionally disturbed has brought focus on the many false attitudes and prejudices of many. It may be that the now unfolding interaction between normal and handicapped children will result in improved images of the abilities and disabilities of the special populations.

Samuel A. Kirk (1978) in his standard introduction to special education states the question with regard to the physically handicapped: "Can a child develop better adjustment in a

school for crippled children, or is it better for him to be in classes for normal children when possible?" Kirk notes that there is little evidence for either point of view, but that the consensus of experts is on the side of placement with normal children. He states the value of partial interaction as follows: "When they (handicapped children) attain security and some independence they can tolerate any problems which arise when they are with nonhandicapped children."

Lloyd Dunn (1968) has argued to abolish special segregated classes for borderline and high-level retarded students, and given challenge to all special educators. He writes, "the conscience of special educators needs to rub up against morality...we contribute to the delinquency of the general educators since we remove the pupils that are problems for them and thus reduce their need to deal with individual differences."

No doubt, leaders in the field of special education who had attitudes paralleling Kirk and Dunn were responsible for the special P. L. 94-142, and that legislation resulted in some major trend shifts in special education. Certainly, the problems of mainstreaming the handicapped or disabled student will not be easy, and for many of the students in special education mainstreaming will be undesirable. However, more special population students are now in partial interaction

with the "normal" student population, and the value for both populations seems obvious. Basically, there is much of value to learn, for both individuals, in any interaction between able-bodied and disabled, old and young, angry delinquent and retarded youngsters.

THEORY AND RESEARCH FROM SOCIAL PSYCHOLOGY

In studies of group composition, working directly with the variable of heterogeneity vs. homogeneity, there are many findings to advocate the desirability of the mixed group. Hoffman (1959) found that the more diverse the personalities within the group the greater the potential for creative problem solving. He suggested that heterogeneous groups were superior to homogeneous groups in "inventive solutions." Tragically, however, Hollinshead (1949) has noted that most high schoolers would prefer homogeneous groupings, and reported that they felt more comfortable in interaction with people of similarity to themselves. This implies that there may well have to be some sort of "forced" interaction, as per Public Law 94-142 in special education, and all the equal rights laws for busing and schooling and housing. Granting, morality cannot be legislated; but the data suggests that interaction can be mandated, and that that interaction will

improve attitudes and behaviors. In any case, it appears desirable to create mixed groups whenever possible, and the special wilderness adventure trip is one possibility.

In one of the more standard textbooks on Social Psychology, Individual in Society, by Kretch, Crutchfield, and Ballachey (1962), there is review of the research under a series of special guidepost statements. I shall not attempt more than to list a few guides, for the reader will readily see the potential application of same to the arguments of heterogeneity vs. homogeneity.

"Guide 16: The attitudes of an individual are shaped by the information to which he is exposed."

"Guide 17: The group affiliation of the individual helps determine the formation of his attitudes."

"Guide 20: Attitude change is brought about through exposure to additional information, changes in the group affiliation, enforced modification of behavior toward the object, and through procedures which change personality."

"Guide 22: The effectiveness of new group affiliation in inducing attitude change is a function of the characteristics of the group and the nature of the individual's membership in the group."

"Guide 33: A group comes into being to achieve the wants of its members; in the course of interaction the members develop a group ideology which regulates their attitudes and actions and influences their satisfaction."

"Guide 34: In all groups, the positions, roles, and powers of the members become differentiated and organized into a system-the group structure-which influences the functioning of the group and the satisfaction of the members."

Bennis, Schein, Berlew, and Steele (1964) have presented a fascinating collection of theory, research, literature, and commentary on human interaction and its impact on the self-concept and social functioning of the individual. These authors note that in the heterogeneous group "the validity of our beliefs is often challenged by the different beliefs of other people," and that this challenge leads to personal attitude/personality change and re-organization. My suggestion is simply that group leaders might value from review of much of the research in social psychology, and that there might be much food for thought in considering group composition for the adventure trip.

GROUP PSYCHOTHERAPY AND PERSONAL GROWTH GROUP PROCESS

Group psychotherapy, essentially implying a

professional treatment/counseling program for individuals with emotional or mental disorder, dates back to the 1930's. Slavson (1947) reviewed the unfolding trends to mid-century, and noted that the issue of homogeneity vs. heterogeneity was obvious. He reports that while many therapists are restricted in the range of patient types with whom they work, often specializing in work with schizophrenics, or a prison population, or in a clinic that focuses on therapy for neurotic individuals, many still advocate mixing the group as much as possible. The argument for "variety" in the therapy group is well stated by Wolberg (1954) who advocates that a mixture of different patient types "permits the members to observe a wide assortment of defense mechanisms and to experience tensions they might otherwise evade."

Luchins (1964) notes that the question of homogeneous or heterogeneous grouping depends on factors such as the goals of the therapy, the therapist, and the setting within which the group unfolds. With regard to the issue of mixing more handicapped patients with those who are better adjusted and further along in their own rehabilitative recovery, Luchins writes, "some patients find it reassuring to be with individuals who are recovering and frequently the better patients try to help the poorer ones." He concludes that "no group is really homogeneous," as there are always differences of some kind.

The group is a "unity of differences, the very existence of which helps to make things move."

The essential beginnings of "personal growth groups" can be traced to the students of Kurt Lewin, working out of Massachusetts Institute of Technology and the University of Michigan, and developing the T-group laboratory method in the late 1940's. This work was in temporal proximity to the efforts of Carl Rogers and his students at the University of Chicago. The basic distinction between the more traditional group therapy as treatment orientation and that of the new group processes for growth was the broader range of persons served. Growth groups were for everyone, although most of Rogers early work focused on the college campus. Laboratory groups were offered for leaders of business and industry, for educators, and for anyone wishing to enhance their personal development. By their very nature, these groups were sometimes offered to very homogeneous populations, such as the middle management executives of a specific company; but they were often offered without concern for the unique life state, problems, value-orientation, and motivations of participants. In general, heterogeneity was the nature of group composition.

Rogers (1970) emphasizes the value of heterogeneous grouping as the group evolves in the direction of an all for one healing base. He notes,

"One of the most fascinating aspects of any intensive group experience is to observe the manner in which a number of the group members show a natural and spontaneous capacity for dealing in helpful, facilitating and therapeutic fashion with the pain and suffering of others. This kind of ability shows up so commonly in groups that it has led me to feel that the ability to be healing or therapeutic is far more common in human life than we suppose. Often it needs only the permission granted-- or freedom made possible-- by the climate of free-flowing group experience to become evident."

The professional work experience background of the present author is twofold, in special education work with students, parents, and staff, and in the application of personal growth groups to staff training and educational curriculum. In my experience in the facilitation of special outdoor adventure trips and outdoor therapy workshops, I draw heavily from my work with group therapy and with personal growth groups. There is no doubt in my mind that special group excursions, be they a few hours or a few weeks, can be designed and facilitated in a manner quite like that of the personal growth group. If I can set the stage to provide the freedom that Rogers mentions, and create an expectancy of tribal "we" for the tasks to be covered, then people will rise to the challenge of dealing with

each other in a helpful and growth producing manner. Furthermore, the troubled teenager will reach out to help the old man, and the youngster with emotional problems will reach out to give needed assistance to the blind traveler.

PROBLEMS OF THE HETEROGENEOUS GROUP ON THE OUTDOOR ADVENTURE.

My thesis has been that there is value in heterogeneous grouping for the outdoor adventure trip. While there is no great body of empirical data to support this thesis, there are theory and data from the fields of special education, social psychology, group psychotherapy, and the personal growth group movement that give credence to the idea. More importantly for this author, there is a wealth of personal experience that leads me towards guiding mixed groups whenever possible.

There are, of course, some special considerations/problems in guiding extremely heterogeneous groups on the adventure trip. First, there is the problem of the whole group being limited to the extent that the group has to deal with the limitations of that slowest/lowest participant. The limitations can be of travel time, or of the very nature of the excursion. A few hearty teenagers could cover a 10-mile canoe trail, including a difficult portage, in a few hours, whereas an older traveler or a traveler that uses a

wheelchair might require two or three times as long. Likewise, a group of college students might be able to paddle through a rough stretch of whitewater, but younger, less experienced, emotionally disturbed children could not.

When I first considered this problem, I realized that it was really not unique for the heterogeneous group. I have been with groups of adults, all able-bodied, where paddle-power and travel capability varied greatly, and the stronger, faster, more skilled adventurers had to wait on or assist the less capable. Of course, leaders try to pair up the participants in a manner that balances the group (as having the strongest canoe with the weakest), but there are always differences. In the heterogeneous group, the leader may well have to know the limits of participants even better and create traveling matches that insure safety and minimize intra-group lag.

Another attack on this problem is to create differential expectancies. I have often sent a couple of canoes ahead to locate best campsite, chop firewood, and ready the camp for the slower in travel. I have also had the total group take safer and more restricted courses, such as a shoreline instead of open water, in order to create greater problems of differential paddle skill/strength in high winds. I would certainly seem to be the leaders job

to try and minimize the whole problem of too great difference between the group members.

A second problem for the heterogeneous group, not altogether unrelated to the first, is that of development of cliques. In a group with 3-4 teenagers, for example, they may tend to separate from the rest of the group. This, of course, undermines the whole purpose of complex interaction between all members of the group. I am not usually the type of leader to aggressively require that the more able-bodied help those with greater need, for I seek that very important lesson to come up from within the group itself and the individuals therein.

I tackle this problem in two ways. When possible, I spend a few days in tribe-building before the wilderness adventure. We visit, or set-up, ropes and teams course obstacles, and get about a number of tasks that bring involvement and group cohesiveness. I have even found value in a crowded-in-van travel arrangement, for people are then forced into close interaction that builds up relationships for the trails ahead. The second way I tackle the problem of cliquing is to design the adventure trip so as to allow that to happen sometimes (e.g., letting a subgroup

take off on a solo trip one day or overnight, separate from the rest of the group), but programatically deny splintering at other times. Subgroup cliques can be discouraged if there are total group meals, not the more typical subgroup foursomes, and if there are assigned times for the total group to meet for special experiences and for processing the happenings. In any case, the leader can design-out opportunity for splintering.

A third problem in broad scale heterogeneous groups on the wilderness trip has to do with the broad range of interests. Some may seek more stress and challenge, while others are more inclined to wish for relaxation and interpersonal interaction. Some may be more interested in the nature hikes, others in the moments of rock climbing and boulder diving. Some are into fishing, others want to sunstretch, and still others sleep the day and stay up at night to talk to the stars. The group must provide opportunity for a range of happenings, so that some of each person's needs will be met. At final campfire, on closing night of our adventure trips, we often review highlights. One may say, "I wish we could have done lots more rapelling, that was great," and another would say, "The best was the day we canoed in the wind." Someone else might voice their preference for the nighttime

campfire and the indian stories, whereas the highlight for another was the discovery of moose droppings in the forest. When I listen to such commentary I am always filled with amazement, for even though the group did not exist solely for any single individual, it somehow accomplished something special for each member. Perhaps that is the essence of the heterogeneous group on the wilderness trip. No matter how broadranged the many individual differences, the "I" becomes the "We" for the duration of the adventure, and from the shared experience the "We" gives so much back to each and every "I" on the journey. Certainly, for me, those trips with heterogeneous grouping have continued to enchant, enrich, and enthrall.

REFERENCES

- Bennis, W. G., Schein, E. H., Berlwe, D. E., and Steele, F. I., INTERPERSONAL DYNAMICS, Homewood, Ill., Dorsey Press, 1964.
- Deutsch, M., and Collins, M. F., INTERRACIAL HOUSING: A PSYCHOLOGICAL EVALUATION OF A SOCIAL EXPERIENCE, U. Minnesota Press, 1951.
- Deutsch, M., "Co-Operation and Trust," NEBRASKA SYMPOSIUM ON MOTIVATION, University of Nebraska Press, 1962.
- Dunn, L. M., "Special Education for the Mildly Retarded: Is Much of It Justified?", JOURNAL OF EXCEPTIONAL CHILDREN, Vol. 35, 5-24.
- Hoffman, L. R., "Homogeneity of Member Personality and Its Effect On Group Problem Solving," JOURNAL OF ABNORMAL AND SOCIAL PSYCHOLOGY, Vol. 58, 27-32.
- Hollingshead, A. B., ELMTOWN'S YOUTH, New York, John Wiley & Sons, 1949.
- Kelly, H. H., Hastsof, A. H., Jones, E. E., Thibaut, J. W., and Usdane, W. M., "Some Implications of Social Psychological Theory for Research on the Handicapped," PSYCHOLOGICAL RESEARCH AND REHABILITATION, American Psychological Association Conference Report, 1960.
- Kirk, S. A., EDUCATING EXCEPTIONAL CHILDREN, Houghton-Mifflin Co., 1978 Edition.
- Kretch, D., Crutchfield, R. S., and Ballachey, E. L., INDIVIDUAL IN SOCIETY: A TEXTBOOK OF SOCIAL PSYCHOLOGY, N. Y., McGraw-Hill, 1962.
- Luchins, A., GROUP THERAPY: A GUIDE, N. Y., Random House, 1964.
- Mead, G. H., MIND, SELF, AND SOCIETY, University of Chicago Press, 1934.
- Rogers, C., ON ENCOUNTER GROUPS, N. Y., Harper and Row, 1970.
- Slavson, S. R., THE PRACTICE OF GROUP THERAPY, International University Press, 1947.

Smith, T. E., WILDERNESS
BEYOND...WILDERNESS WITHIN,
McHenry, Illinois,
McHenry Press, 1981.

Wolberg, L. R., THE TECHNIQUES
OF PSYCHOTHERAPY, N. Y.,
Grune and Stratton,
1954.

CIRCUIT TRAINING: TOTAL PHYSICAL FITNESS FOR PERSONS WITH DISABILITIES

DALE E. ABELL
VINELAND NATIONAL CENTER
LORETTO, MINNESOTA

INTRODUCTION

Physical fitness has moved from a fad of the seventies to an accepted lifestyle of the eighties. Over the past ten years, there has been a tremendous increase in the activity level of millions of Americans. A new kind of athlete has emerged in this country; not olympians or necessarily even members of special teams (Ferguson, 1980). These athletes are men and women of all ages and abilities. Some with diagnosed chronic illnesses, some with physical disabilities, most with no apparent disability. The common denominator that exercise enthusiasts share is an appreciation for the psychological and physical benefits of fitness.

The benefits of regular physical exercise are as many and varied as the persons who participate. Some of the benefits that research has documented include: improved self esteem, an aid in weight reduction, moderation of self-abusive habits (i.e., smoking, alcohol consumption, overeating), increased mental and physical energy, and as an aid in the prevention of coronary heart disease. Exercise prescriptions are a part of the treatment regimen in a great many diseases including heart

attack, arteriosclerosis, hypertension, diabetes, obesity, depression, and anxiety (Thomas, et. al., 1979). These diseases are, in many cases, a secondary and complicating disability for persons who already have a congenital or traumatic physical disability.

Until recently, persons with physical disabilities have not been encouraged to exercise, thus increasing rather than preventing their chances of contracting a secondary disability. Overprotective attitudes by human service professionals and family members, resource inaccessibility, and a lack of properly adapted equipment have traditionally been the most predominant reasons that persons with physical disabilities have not regularly exercised. Through a greater exposure and awareness of the benefits of exercise, persons with disabilities are gaining much more access to regular exercise and training opportunities.

The bulk of the training that now takes place has an emphasis on aerobic activities. Aerobic exercises have the greatest benefits in the area of cardiovascular fitness and endurance. From a health standpoint, this

makes aerobic training the most important type of activity that one can do to improve fitness. Each year nearly one million Americans die from diseases of the cardiovascular system, accounting for as much as 55% of all deaths in this country. Many researchers now believe that training and conditioning of the cardiovascular system can be very helpful in reducing an individual's risk to these diseases. A total physical fitness program, however, must include exercises that improve muscle strength, muscle endurance, and flexibility as well as cardiovascular endurance exercises. Circuit training can play an important role in a well rounded fitness program.

IMPROVING FLEXIBILITY, STRENGTH, AND ENDURANCE

Flexibility exercises include stretching and other exercises which prevent the shortening of muscles and improves their range of motion. Shortened muscles can create slowed muscle response, and possible injuries, and are caused by the natural aging process (Anderson, 1979). It is therefore, wise to properly stretch the muscles used before and after any training activity. As with flexibility exercises, muscle strength and endurance exercises are often overlooked by many people currently involved in fitness programs. Strength plays an important role in improving endurance (both cardiovascular and muscular). The stronger the

muscle, the less it must exert itself when involved in endurance activities. To build strength the muscle must be overloaded, that is, exerted beyond its usual limits. The most common type of exercises used for muscular strength and endurance is weight training.

Strength-building exercises are the main focus of exercise circuit training. However, if a training circuit is set up properly it can be one of the best forms of total physical conditioning. All of the major muscle groups can be exercised to their limits while at the same time cardiovascular endurance and flexibility will be improved. There are three ways to overload the muscles to make improvements in strength and endurance: 1) increase the exercise resistance (difficulty) beyond the muscle's usual capacity; 2) increase the speed at which the muscles contract; 3) increase the number of repetitions that are done, using the same resistance (Sobey, 1980). A total physical fitness program can be achieved through circuit training by incorporating stations which use these three means of overloading, stretching and range motion stations, and a proper warm-up and cool-down before and after doing the circuit. By moving rapidly from station to station and vigorously doing the exercises at each station, it is possible for participants to maintain their individual

training heart rate.* This improves one's aerobic capacity and cardiovascular endurance while at the same time improving muscular strength, endurance and flexibility. In addition to being a total physical fitness program, another attractive aspect of circuit training is that one can participate in it on a regular basis without specialized equipment or facilities. Many of the stations used can be put together at a minimal cost, with materials that are already available.

PLANNING A CIRCUIT TRAINING PROGRAM

When planning a training circuit, take a careful look at the individual needs and abilities of the persons who

*To calculate your individual training heart rate, use this formula: $220 - \text{your age} = \text{maximum heart rate}$. $75\% \times \text{maximum heart rate} = \text{training heart rate}$. Plus or minus 10 heart beats per minute is considered the 'target zone' for obtaining aerobic benefits from exercise. Take your pulse by locating the carotid artery (neck) or radial artery (inside of wrist). Count the number of heart beats in ten seconds and multiply by six. This will give you the number of heart beats per minute. If aerobic benefit is a goal, it will be necessary to schedule periodic pulse checks to make sure that everyone is exercising within their target zone.

will be using it. In his text, The Complete Circuit Training Guide, Edwin Sobey (1980) provides many ideas for setting up several types of circuits (i.e., indoor, outdoor, and in weight rooms) for individuals and groups of able bodied persons. When planning a circuit it is important to remember that the principles of fitness that apply to able bodied persons generally apply to persons with disabilities as well. There are a few instances, however where special precaution must be taken (see Safety Considerations). The facilitators must be very sensitive to individual needs, make adaptations based upon these needs, and always accept suggestions from the participants. Consult with a physical therapist (preferably one who appreciates the benefits of regular exercise) for specific information about who should or should not do the various exercises.

The circuit outlined here has ten stations and has been found to work well with a group having mixed abilities. The stations are spaced around the periphery of a large room. If the room is large enough or if the circuit is set up outside, it is advisable to place the stations far enough apart so that rapid movement between stations will give the participants who cannot or should not participate in the circuit, a smaller, more individualized circuit with fewer stations can be set up in the center of the room. A physical therapist, for example,

can work in a small circuit on isolating and relaxing muscle groups, range of motion, stretching, or other activities with persons for whom muscle strengthening is contraindicated.

When designing a circuit, it is important to make sure it fits the needs and abilities of those who will use it. Experiment with the location of stations, the length of time spent exercising at each station, and the types of stations, until a circuit is formed that meets the needs of those who will use it. Above all, listen to comments and suggestions from the users. The list of resources provided have many excellent examples of circuits and individual exercises that could be included.

CONDUCTING THE CIRCUIT

Everyone should completely warm-up all of the muscles that will be used before starting the circuit. This will take a minimum of 10-15 minutes. The activities of a proper warm-up should gradually increase in intensity and result in working up a light sweat. The type of activity used will vary depending upon resources available and abilities of the participants. It is best to begin with something that will gradually increase the heart rate. Some examples: jumping jacks, rope skipping, jogging, fast walking or wheeling, stationary bicycle (mounted on a table for wheelers) lying on the back and

'bicycling' with the legs, rapidly moving arms in circles, active games, and vigorously throwing balls. Other warm-up activities can be just as beneficial. The most important factor, however, is that all of the major muscle groups used during the circuit be warmed up.

If stretching exercises are to be included in the warm-up phase, they should be done only after 10-15 minutes of vigorous activity. It is important to note that stretching alone will not warm-up muscles or lubricate the joints. Stretching cold muscles could result in injuries.

After a complete warm-up, participants are ready to start the circuit. Exercise at each station is divided into active/inactive (exercise/rest) phases: 45 seconds active/15 seconds inactive; 45 seconds active/30 seconds-move to next station. The 45/15/45/30 second sequence has been found to work best with a group having mixed abilities and disabilities. The times must be varied to suit the needs of different groups.

Music can be played on a cassette player during the 45 second active phases. The 15 or 30 second phases in the music are the signals for participants to either rest or move on to the next station. This can be done manually or by recording the pauses in appropriate places on the tape. A person with a watch and loud voice can also call out the commands to exercise, rest, move to the station.

The music, however, seems to provide a more pleasant and less threatening environment.

When beginning any new exercise program, participants should be cautioned to start at less than 100% effort until each knows how hard they can safely push themselves. Always increase the duration

(the actual time doing the exercise) before increasing the resistance (adding weight) (Sobey, 1980).

The following are descriptions of ten stations that could be used for circuit training. This circuit has been found to work well with a group of persons with mixed disabilities. It can be modified to fit individual needs.

1. STATIONARY BICYCLE
For wheelers, use 'C' clamp to hold the bike on the table. Toe clips are necessary for some persons, others may need a velcro strap to hold their feet and ankles on the pedals.

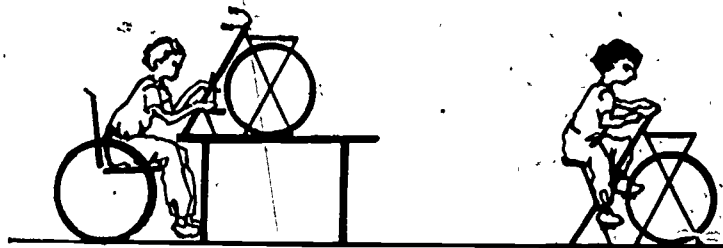

2. BENCH PULL
Two benches are needed. Lay one on top of the other at a 90 degree angle. Adjust the incline according to the strength of the participants. Use a towel or other cloth material to avoid splinters and reduce friction.

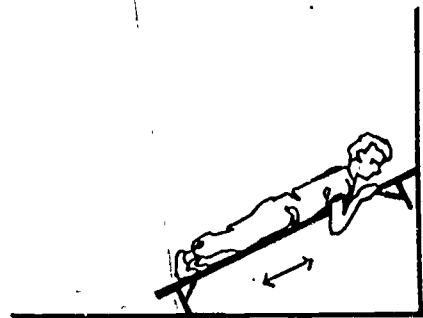

3. SIDE LEG LIFTS
While laying on a mat on your side, bend lower leg at the knee, press upper hip forward, and lift upper leg. With assistance, this can be used as a range of motion exercise for those with limited lower body function.

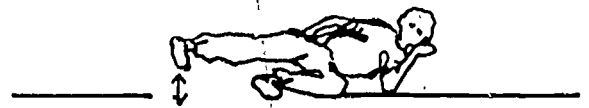

4. SIT-UPS
With the knees bent and feet flat on the floor, initiate the sit-up with your head, roll up and down. For those with limited trunk strength, an inverted chair used as a back support often makes a partial sit-up possible.

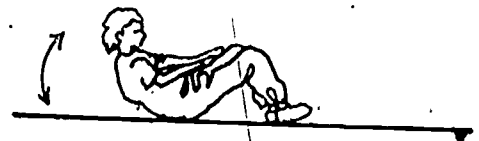

5. FREE WEIGHTS

Use a pillow under your stomach in the prone position. Next 45 seconds in supine position. Choose a weight that you can do 8-12 repetitions with the last three being difficult. Select lifts that best suit individual needs.

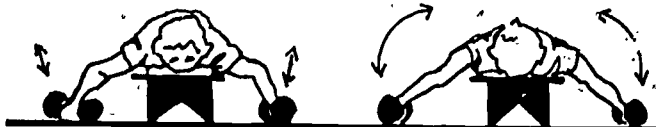

6. EXERGENIES

Can be used for a variety of strength building exercises. Most often used-the cross country ski movement. Wheelers may need to block the wheels of their chair. (Available from Apollo Products, #505 Third Av., Spokane, Washington, 99202).

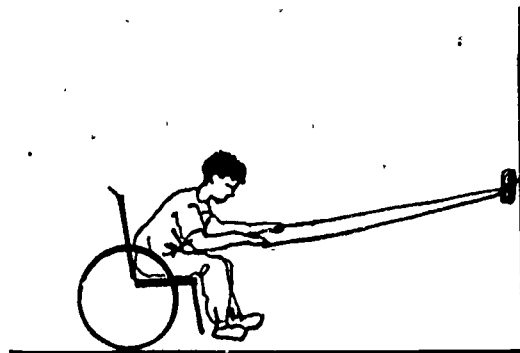

7. EXTENSOR LEG LIFT

With your knees on the floor, prone position to the bench, lift one foot at a time, knees bent. Alternating with knee bent and knee straight.



8. TWO POINT COORDINATION

While on all fours, extend one arm and leg on the opposite side, hold, then change. For some, a spotter will be necessary, for others, an added 'bump' on the hips is necessary to make it challenging.

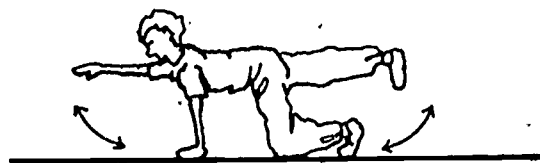

9. SET-UPS

Use a block or bench that has a suitable height, alternate the first foot and step up and down rapidly.

OR

WRIST-ARM STRENGTHENING

Attach a 1-5 pound weight to a 3' long rope and tie the rope to mid-point of an 18" dowel. Extend arms and using a wrist motion, wind the rope on the dowel raising the weight-lower and repeat.

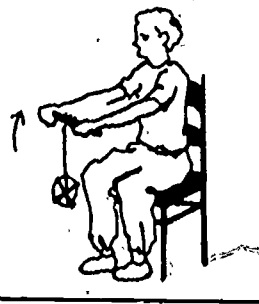
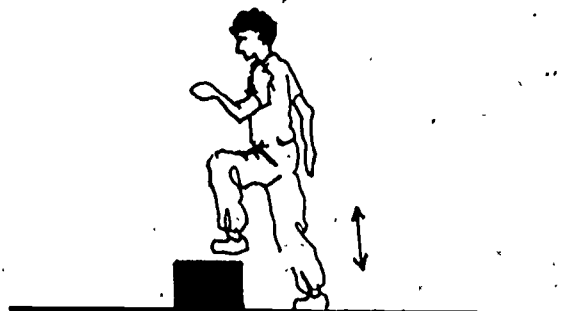

10. PUSH UPS OR DIPS

Choose whether you'll do the dips between two chairs or push ups against the floor. Knees straight or knees bent, depending upon ability.

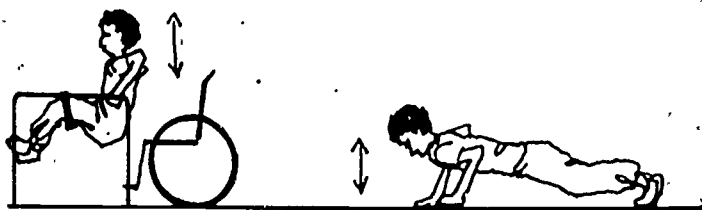

The above stations can easily be adapted to many environments (home, outdoors, camps, weight rooms, etc.) with a minimal amount of equipment. Other stations should be substituted to meet individual needs and/or fitness goals.

Some ideas to consider which may even further eliminate the need for sophisticated and/or expensive equipment:

1. If flexibility and increased range of motion are goals, design a circuit which only includes these exercises. No special equipment is needed.
2. Include exercises in which the body provides the resistance not special equipment (e.g., sit-ups, push-ups, pull ups).
3. Use chairs, benches, tables to increase resistance with push-ups, dips, etc.
4. Use plastic bleach, milk, or soap bottles filled with water or sand as a substitute for free weights. Attach to the ends of a broomstick to make barbells.

5. Partially fill a plastic bucket with sand or water and use for leg lifts.

6. Use an old bicycle inner tube attached to a doorknob for upper body and arm exercises (exergenie substitute).

7. Use your imagination, look around you and you will see other items that could be used.

After any vigorous exercise it is important not to stop abruptly. Just as the body benefits from a gradual increase in activity (warm-up) prior to physical activity, a gradual tapering off of activity and stretching at the end of a workout has positive effects. Return to the resting state following activity is not instantaneous and a proper cooling-down period is important. Participants should be encouraged to continue mild activity until the body returns to its resting state. By monitoring pulse rates before, during, and after activity one can learn to determine when the body has returned to the resting state.

STRETCHING PRINCIPLES

1. Never stretch to point of pain.
2. Never ballistic (bounce) stretch.
3. Stretching should be static and steady.
4. Don't compare yourself to other people.
5. Don't hold your breath.
6. Think about the stretch, tell yourself to relax.
7. Hold the stretch for 20-30 seconds.
8. Warm up briefly before stretching. (This will be accomplished if done after circuit training.)
9. Stretch before and after activity.
10. Stretch-Relax-Hold-Stretch.

(Anderson, 1980)

SOME METHODS OF TESTING PROGRESS

The simplest way to measure progress is to record your repetitions and/or weights at each station and chart the results over a period of time. Over a period of six to ten weeks, there should be gradual improvement. Another way to test total fitness is to run, wheel, or walk an outdoor exercise circuit. By recording the total elapsed time and the degree of difficulty or number of repetitions completed for each station you can, again, gauge your improvement.

Taking your pulse immediately after workouts provides you with another index of training. If you do the same circuit regularly for a long period of time, your pulse rate after working out should slowly decrease. If not, you need to either pick up the pace during the circuit training or add some form of aerobic training to the workout schedule. Another possibility is to devise a test that fits individual needs. However, remember to establish a standard with which you will be able to compare later improvements.

The benefits of testing are mostly psychological. If participants can see improvements, it is likely that they will be encouraged to continue and try harder. If testing shows no progress, hopefully, they will be awakened to the need to work a little harder. It is important to remember, however, that improvements in physical fitness comes slowly. Much more slowly than most would like. A person who has been sedentary for twenty or thirty years should not expect dramatic results in two or three weeks. Luckily the human body is very forgiving and results will come with persistence and determination.

SAFETY CONSIDERATIONS

1. Any large variation in pulse rate or blood pressure taken under similar conditions should be monitored closely and reported to a physician.

2. Participants should be encouraged to drink fluids before, during, and after strenuous exercise. This is especially important during hot weather.
3. A proper warm-up and cool-down will aid in the prevention of injuries.
4. All training programs should be individualized as much as is possible. It is not possible to classify all individuals with the same disability as having the same needs, since each disability has varying degrees of severity. However, the following are some general considerations. Consult a physical therapist for more specific information.

Arthritis

Most often weight training is contra-indicated for persons with arthritic joint involvement. If the joint involvement is minimal, training with weights is still possible. Exercises that utilize lower weights and higher repetitions are advised only after a thorough warm-up and static flexibility exercises.

Cerebral Palsy

Spastic muscles should not be involved in strength training. This only increases the intensity of muscle spasms. Practice in isolating and relaxing spastic muscles is a good option to strength training.

Multiple Sclerosis

Generally, be cautious not to over-exert. Training should be kept to a maximum of 20-30 minutes followed by 30 minutes of relaxation (lying down without distraction).

Muscular Dystrophy

The goal should be to maintain present range of motion and strength. Muscle strength lost to M. D. cannot be regained. Encourage, but do not push beyond present limits. Watch for signs of fatigue; encourage a rest period after the workout.

Diabetes

Consult with a physician prior to beginning a training program. Most diabetics can greatly benefit from regular exercise, however, their diet may need to be modified. Always have fruit or other sources of sugar available while exercising.

Visually Impaired

Unless there is a secondary disability, having a guide will be the only adaptation necessary. Inform the participant of the location of hanging bars, protruding benches, etc. Try not to move equipment once it is in place.

Cardiac Disorders

Exercise must be prescribed by physician, preferably a cardiologist who appreciates the benefits of exercise. Monitor the rate of tolerance to physical exercise carefully. Teach the person to take own pulse for monitoring body's

response to exercise. Cardiac exercises are specifically prescribed to meet the many different levels of cardiac decompensation. Treatment depends on the person's ability to perform with proper regard to fatigue and work tolerance levels.

Spinal Cord Injured

Caution participant about preventing pressure sores. Extra cushioning may be needed on chairs, benches, or floor. Often exercises can be adapted and done in the wheelchair, however, the practice of transferring is beneficial to most persons who use wheelchairs.

Hemiplegia

Monitor the rate of physical exercise carefully, consult with a physician regarding participant's ability to perform in reference to fatigue and work tolerance level. Use of a 'grip mitt' may enable bilateral use of equipment. Use caution with free weights since poor grip strength may cause weights to be dropped on toes or others.

CONCLUSION

Training circuits are adaptable to the needs of persons with a wide range of abilities. Circuits can vary in length, number of exercise stations, type of exercises, and degree of adaptations and modifications.

Circuit training can be used to reach many fitness goals. Muscular strength and flexibility are the most obvious, however, if conducted at a brisk pace, participants can improve cardiovascular endurance as well.

Circuit training is also an excellent way to add some variety to other training regimes. Circuit training can be used indoors during inclement weather when one might otherwise go outdoors to run, bicycle, etc. By participating regularly with a group, there are also social benefits as well as the chance to learn from others. Individualized circuits do not have to cost a lot of money to be effective. Most stations can be set up with a minimal cost by using materials which are readily available. By utilizing available resources, a little creativity and listening to suggestions from the users, circuit training can become an integral component of any total fitness program.

REFERENCES

- Abell, D., "Circuit Training," Fitness Training: A Guide to Aerobic Exercises for Persons With Disabilities. The Viiland National Center, Loretto, Mn., 1982.
- Anderson, B., Stretching, Shelter Publication, Bolinas, Ca., 1979.
- Benyo, R. and Proyost, R., "Staying Indoors", Runners World Presents, Summer, 1982, pp. 73-81.
- Bjornaara, B., Weight Training Systemetized, The Croixside Press, Stillwater, Mn., 1975.
- Ferguson, T., "A Field Guide to Exercise", Medical Self Care, Simon and Shuster, New York, N. Y., 1980.

Sobey, E., "Aerobic Weight Training", Runner's World, August, 1981.

Sobey, E., Strength Training Book, Anderson World, Inc., Mountain View, Ca., 1981.

Sobey, E., The Complete Circuit Training Guide, Anderson World, Inc., Mountain View, Ca., 1980.

Thomas, G., Franks, P., Lee, P., Paffenberger, R.
"Exercise and Health: The Evidence and Policy Implications", Health Policy Program (School of Medicine, University of California), San Francisco, Ca., 1979.

RISK TAKING AS AN EDUCATIONAL TOOL

MARDA GILMORE BUREAU
 PRETTY LAKE ADVENTURE CENTRE
 KALAMAZOO, MICHIGAN

The Pretty Lake Adventure Centre (PLAC) operates on a year round basis and is dedicated to providing special types of education, based on adventure experiences in the outdoors. Utilizing ropes courses, a 50-foot climbing and rappelling tower, initiative areas, and many off-site workshops, PLAC is an experiential program designed to enhance group and personal growth. The main goal of PLAC is to increase in each individual the capacity for self-responsible living by improving their ability to direct, support, and actualize their lives.

PLAC AND CHILDREN WITH EMOTIONAL IMPAIRMENTS

The approach at PLAC is a realistic one, consistent with the underlying purpose of all education: development of the child's ability to think, and to keep growing as a whole person. Presently, PLAC is developing a treatment division, which will expand programs to include youth with social and emotional impairments. According to the Michigan Special Education Rules amended August 13, 1980, an individual may be labeled emotionally impaired (EI) if the manifestation of behavioral problems seriously impairs patterns in the affective domain. The affective domain of the

EI youth may be characteristically exhibited by:

1. Inappropriate types of behavior under normal circumstances.
2. An inability to build or maintain satisfactory interpersonal relationships.
3. A general pervasive mood of unhappiness or depression, to the point it interferes with the learning process.
4. Developing physical symptoms of fear associated with personal and school problems.

PROBLEMS OF LABELS

Emotional impairment has many causes. The educational system itself can cause E. I. Some students enter school and face tasks for which they are not ready. They have difficulties which result in legal and professional labels being attached to them. These labels spring from an inexact professional vocabulary which means different things to different people. Education and support professionals typically see all the difficulties of an individual, and none of the opportunities for that individual. Remedial and treatment programs are provided for individuals

who are not failures in themselves. They are simply defined by the label we confine them to and limited by the educational system itself.

As children grow and mature, their self-concept is determined and molded, to a large extent, by other people's perception of them. The behavior patterns of many children, therefore, are dictated by what they believe to be the expectations of others. These expectations and assumed behavioral parameters eventually create self-imposed limitations and boundaries on the child's actions. The child feels safe and comfortable acting within the perceived "acceptable limits," but fears to challenge and exceed the imaginary and learned behavioral expectations.

Brown (1971) called the inability to actualize feeling with no guarantees the "process of deadening." He stated: "As this process of deadening persists, we lose touch to the extent we are no longer aware of what we really feel. We eventually reach a point where we have little choice about how we behave; for deprived of feelings tell us what we want or don't want, we react primitively, compulsively, and ritualistically."

FEAR AS A DETERMINANT OF RISK TAKING

Timmerman (1975) stated: "The bigger we get the more we want to wander around in the world to look

and see. The more we look and see the more we grow. It is a never-ending circle. The only thing that hinders us from looking over the fences is...fear."

This fear is internal and supported by a system of thought which is utilized to justify actions and avoid "self risk taking. Therefore, placed in an unfamiliar situation, the child's intellectual process actually becomes a fear or risk-based avoidance system.

We at PLAC feel that all fear is painful, but can be positive factor when challenged in a safe situation. A challenged fear can be dealt with and understood by the individual. Every consideration, therefore, by which groundless terrors may be removed adds something to human happiness. One can never conquer fear or feel the self-gratification in doing so until one risks behavior that confronts the fear. "Like a child afraid of the dark, you are afraid of nothing, because nothing is the worst thing that could happen (Dyer, 1977)." It is felt that children can be emancipated from these fears...by educating them in taking risks. Fear arises out of ignorance of the fear itself and not understanding how to confront it.

At the Pretty Lake Adventure Center, it is a fact that the basic primal risk is that a person will change. Security, no matter how sustained by the denial of reality, seems preferable to an individual over what

might happen to them. But before the individual can learn anything, it is essential to be willing to be exposed to a new experience, to relinquish the security, and risk to a change in self. According to Robert Knerr (1979), risk-taking is defined as: "The capacity to actualize feelings, thoughts and actions with no guarantees or previous experience." This is the definition of risk-taking as used at PLAC.

DEVELOPING RISK-TAKING PROGRAMS

The educational establishment should recognize and develop programs with risk-taking having an integral part. If the educational establishment can view a person's behavior as rising out of a need, and then identifying that need, they can go far toward understanding, accepting, and teaching that person how to use a risk taking as a tool of self-growth.

Learning is enhanced when fear is removed. The goal of education based on that assumption is to remove the fear that makes self-doubt questions crucial to the student. The student who is afraid of failing, operates from a fear based lack of motivation, which blocks accomplishments and insights.



"..the basic primal risk is that a person will change."

Each of us can point to at least one event in our life, when we made the discovery that something we believed to be true, in actuality was false. This is the beginning of opportunity for real learning...the turning point.

Wood (1974), said: "If I never try anything, I never learn anything. If I never take a risk, I stay right where I am. If I hold myself back, I trade appearances for the opportunity to find out what I am really like."

How can we know when the individual feels safe enough to dare to choose the new step forward? Growth usually takes place in little steps and each step forward usually comes from a feeling of being safe. Assured safety permits higher needs and impulses to emerge and to grow towards mastery. It reaches a point where no one individual can make a decision for another individual. He or she must start trusting their own experience, realizing that evaluation by others should not be a prerequisite. Other opinions can be considered, but the only person who knows what they are doing is the individual. He or she can either hide behind a façade, or can take the risks in becoming himself or herself.

In recent years, personnel at PLAC have come to understand the crucial importance of self-concept in affecting every aspect of a person's life. It is time to recognize that, for many individuals, there is a vacuum outside the school, devoid of intense experiences which result in self-knowledge and growth. "We can learn. Man is capable of growth and maturity. And our social

institutions, the educational system, at least must change its ways toward the end. It can do that by recognizing the importance of affective or emotional learning as a primary educational function" (Brown, 1971). If one can add an emotional dimension to learning, the learner will become personally involved; and, as a consequence, there will be a change in the individual's behavior. This encouragement of self-concept building, the use of risk-taking, is the cornerstone of PLAC programs.

Educators need to be trained in risk-taking! It is the right of the student to be made aware of the choices available in risk-taking and risk-taking is a vital and indispensable part of any educational setting. The educational establishment has the responsibility to design learning environments containing experiences which allows individual self-knowledge to grow.

The benefits of risk-taking are for all populations... It is time to realize that all people have the right to create their own identities if they are to function effectively in a demanding and competitive society. The Pretty Lake Adventure Centre staff feel that risk-taking is essential for an individual to live the fullest physical and mental life possible.

REFERENCES

Brown, G., Human Teaching
for Human Learning:
to Confluent Education,
the Viking Press,
N. Y., N. Y., 1971.

Knerr, R., Bacstop, Battle
Creek Public Schools,
Battle Creek, Michigan,
1979.

Timmermann, T., Growing Up
Alive, Mandala Press,
Amherst, Massachusetts,
1975.

Wood, J., How do you?
Prentice-Hall, New
Jersey, 1974.

"UTILIZING HERITAGE ARTS WITHIN OUTDOOR EDUCATION EXPERIENCES"

KAREN SCHULTZ AND JAN BEAMAN
NORTHEAST DUPAGE SPECIAL RECREATION ASSOCIATION
CABIN NATURE PROGRAM CENTER
WOODDALE, ILLINOIS

With times changing so rapidly it is often difficult to comprehend lifestyles of the past. Our ancestors devoted many long hours of hard work to create simple household items used every day. When they had a chance to play, their choice of recreation opportunities was much different than ours.

Today, most of our food, clothing and household items are prepackaged and purchased at a store. The origin of these items are frequently forgotten. Children and adults alike often rely on being entertained rather than creating their own fun. Over time, and with modern conveniences available, many every day chores of the settlers have become popular recreational pursuits of today.

Heritage arts activities can provide an exciting "hands on" approach to learning about our heritage. Participants can be involved in pioneer activities designed to increase awareness of local pioneer lifestyles and cultural history.

It does not take an expert to develop meaningful activities for a living history program. Willingness to lightly research local

history, ability to collect "junk treasures", and to take time for pre-program activity trials are the main elements for successful heritage arts programming. Keeping a few points in mind, as well as the specifics in adapting for the population to be involved, you are ready to start into a very exciting program area.

1. Be sure to utilize local expertise and resources. Local senior citizens, as well as the library, are good places to start.
2. Use creative settings and stories to entice participants into the mood for your program. Lead in stories of packing up your wagon train to set out into the wild west, and others of similar nature are great mood setters. The stories help to hold participants' interest on life of 100 years ago.
3. Time is a difficult concept for many to grasp. Utilize short activities before the program to assist in bridging the time gap.

4. Keep the participants actively involved in the imaginative time change. Remember, attention is hard to maintain in a history lecture.
5. When planning activities, remember to keep them age appropriate as well as suitable for fine and gross motor skill levels.
6. Play on the participants' abilities, not disabilities.
7. It is beneficial to have examples on hand when creating a project. This also insures the leader has experimented with the activity beforehand. Often this can avoid a group failure due to inadequate supplies and equipment instructions, and techniques.
8. Station teaching can be a great aid in creating heritage projects. Everyone can be assigned their own space, supplies and equipment. Step by step instructions often help avoid the same question being asked over and over again.
9. Most everyone in the group will have difficulty at a certain stage. Stop and offer assistance. Perhaps individuals participating can lend a hand to their neighbor in return for the same assistance.
10. Use a facility and space appropriate for the activity.
11. Allow enough time for the specific activities to be completed and avoid providing too much time for restlessness to set in. It is better to have too much planned for the program than to have a void in the activity.
12. Set out all supplies and equipment before the program begins. A quick run through of the activity will help you to see if you forgot those one or two important things.
13. Above all, be safety conscience. Simple rules before the activities begin can avoid unfortunate accidents.

In the following section, a few areas that may be included in heritage arts activities are reviewed. A short list of suggested resources are included to be utilized in assisting in the many fine details of heritage arts.

PIONEER COOKING

Pioneers did not have many of our modern conveniences such as refrigeration and "7-11" stores. Discuss with participants where specific foods or ingredients they will be using came from. How were they obtained by the pioneers? Were they available during all four of the seasons? What kind of equipment did they use and did they make or obtain them?

A few ideas to review in developing these types of activities are:

- Can you process the activity within the time slot available or should it be a session format?
- Will you prepare enough of the pioneer foods for the participants to taste, or are you providing an entire meal for them?
- Can some of the high cost food items be substituted?
- Can ingredients be pre-measured to avoid failure?
- Should tasks be assigned to individuals in advance?
- Can you incorporate other desired skill practices into the activity? How about utilizing math, science, or English?

SUGGESTED RESOURCES FOR PIONEER COOKING

Better Homes & Gardens Heritage Cook Book,
Editors of Better Homes & Gardens, Meridith Co., 1975.

Country Scrapbook, Jerry Mack Johnson, Doubleday and Company, Inc.: N. Y., 1974.

Eating In America: A History, Wasnesly Root and Richard Dee Rockemont.

Great Home Cooking In America, Food Editors of Farm Journal.

The American Heritage Cook Book, Editors of American Heritage Magazine.

SOCIAL RECREATION

This area can be a simple introduction to leisure time pursuits that pioneers enjoyed. It can also be a step back into the days before running water, electricity and modern conveniences. Many of the childhood games and songs stem from very rich stories of the real world. "Ring Around the Rosy" is a song about the black plague, "London Bridge," of an Elizabethian prisoner, where as "Here We Go Round the Mulberry Bush" made berry picking fun and games, rather than a chore.

When developing this area remember:

- Tie in the origin of the story or your interpretation of it.
- An activity should be "processed" within the time allotment of the program. That is, discuss with the participants what has happened during the activity as well as progress towards goals and objectives that have been achieved.
- Do participants possess the required gross and fine motor skills to complete the activity?
- Are the activities age appropriate and the skill levels adequate to use required tools or equipment?
- Can you help to develop a leisure pursuit area for the participants through these activities?
- If you are constructing a project to be taken home at the end of the program, can it be transported "as is" and is it labeled with the creators' name?

- Pre-plan to control behavior. Consider simple rules, laying tape marks for dance positions, carpet sample squares for assigned working stations.
- Remember, others' junk can be your treasures. Collect or search for donations to cut costs.
- Above all, try the activity before leading it in a program.

SUGGESTED RESOURCES FOR SOCIAL RECREATION

A Collection of Dances For Children (card file),
Marie Vick and Rosann McLaughlin Cox, Burgess Publishing Co., Minneapolis, Minn., 1970.

American Folk Tales and Songs,
Richard Chase, Dover Publications, Inc., N.Y., 1974.

Corn-Husk Crafts, Margery Facklam and Patricia Phibbs, Sterling Publishing Co., Inc., N. Y., 1973.

Foxfire 1, 2, 3, 4, 5, and 6,
Edited by Eliot Wigginton,
Anchor Press/Doubleday,
Garden City, N. Y.

How to Make Corn-Husk Dolls,
Ruth Wendorff, Arco Publishing Co., Inc., N. Y., 1973.

"Like It Was" Bicentennial Games 'n Fun Book,
Adah Parker Strobell,
Acropolis Books Ltd.,
Washington, D. C., 1975.

Naturally Powered Old Time Toys, Majorie Henderson and Elizabeth Wilkinson, J. B. Lippencott, Co., N. Y., 1978.

The Golden Book of Colonial Crafts, Golden Press, N. Y., 1975.

The Rhythm Band Book, Ruth Etkin, Sterling Publishing Co., N. Y., 1978.

SPINNING, WEAVING AND DYEING

This area leads participants to look into the intricate process of preparing fabrics and clothing during pioneer days. Production of a strand of hand spun yarn and incorporation into a weaving and/or natural dyeing project is possible with almost any population. Projects can be as simple or complex as necessary to be a suitable activity for the intended participants. With this area of heritage activities being the most refined in nature, consult reference books to obtain specific details and gain proficiency before leading desired activities.

Equipment can be expensive to purchase. Several reference texts have suggested substitutions for equipment or plans on how to make your own. With a little background information and experience any programmer can lead fiber heritage activities.

When developing activities within this area, keep in mind the following:

- An individual's creativity and abilities form their expressions in fibers and other materials. Do not strive for perfection.
- Weaving can easily be developed as an individual's leisure time pursuit. Offer enough background instruction so that participants may continue on their own from an introductory program.
- Step by step activities work best when working with a larger group or with a low staff/participant ratio.
- Prefabrication of looms and pre-measured supplies lessen frustration levels and confusion.
- As a part of the activity, analyze with participants where, what and how the pioneers' materials were obtained.
- Utilize resources to familiarize yourself with appropriate terms and methodology. Although they may need to be simplified, these should be included as part of the activities.
- Looms come in all shapes and sizes. Determine the most appropriate type for the participants. Cardboard looms are inexpensive and easy to construct (see description at end of this article). Perhaps the construction could be part of the activity enabling participants to have their own looms at a later date.
- Plastic darning needles or yarn taped to popsicle sticks ease the process of weaving over and under the base, or warp as they are termed, threads. The

- warp threads of the weaving may be laid with alternate colors for simplification (i.e., under yellow, over red).
- Some natural dyeing processes call for toxic chemicals. Be aware of the dangers and take precautions. Onion and carrot skins or spinach do not need dangerous mordants to fix the interesting variety of colors they create.
- Check to see if there is a local sheep farmer. The farmer may be willing to donate raw, uncleaned wool or sell it at a reduced cost. It is not necessary to use clean wool for introducing spinning. The wool should be rinsed several times to remove dirt, bugs, oils, etc.

Weaving, spinning and dyeing can be somewhat involving and time consuming activities. They are a wonderful experience in creativity and are appropriate for any age level or either sex. The reference texts listed below are of great assistance to developing particulars in a fiber program. Check your local library for additional resources.

SUGGESTED RESOURCES FOR FIBER ACTIVITIES

Spinning and Dyeing the Natural Way, Ruth Castino, Van Nostrand Company, N. Y., 1974.

Vegetable Dyeing: 151 Color Recipes for Dyeing Yarns and Fabrics With Natural Materials, Alma Lesch, Watson-Guptill Publications, N. Y., 1970.

SAMPLE HERITAGE ARTS ACTIVITIES

LOOMS

There are many kinds of looms used to weave fabrics. Some looms, which are frames to weave on, can be made very easily.

Cardboard Loom:

Cut 1/2" vertical slits in across the top and bottom of a piece of cardboard. This forms tabs that become a loom. Wrap yarn between the tabs, moving from top to bottom on the front side, keeping the yarn taut. This is called the warp of a loom. Weave yarn horizontally, over and under the warp, to make a design. This is called the weft. Use your fingers or a kitchen fork to push the weft down tight after each row. When filled, stitch through the end loops and release the finished weaving from the loom.

GrapeVine Loom:

A branch, such as a grapevine, can be bent into a loom. Lash the ends together and wrap the warp around the outer edges, tying a half knot each time. Fill the loom with weft and leave it on the branch to hang the weaving up with.

Terms to Know and Use:

Fleece: Fleece is raw wool which has been sheared from a sheep. When you touch it the lanolin leaves a slight greasy feeling on your skin.

Rolag: Wool is cleaned by washing and carding it. Cards comb the dirt out and straighten the fibers. Then the wool should be gently rolled into a log shape.
Handspun yarn: The rolag is then spun on a drop spindle or spinning wheel to make yarn. The fleece is then ready to be woven.

OLD FASHIONED CRACKER JACKS

Supplies: 2 qts. popped corn
2 c. shelled peanuts
1 c. molasses
1/2 c. sugar
heavy saucepan
popcorn popper

Pop popcorn, and mix in a bowl with peanuts. Carefully cook molasses and sugar in a deep saucepan until it becomes thread-like when dropped in cold water (234 degrees). While hot, pour the molasses mixture over the popcorn and peanuts, then thoroughly mix. Let cool before eating.

CHURNING BUTTER

Supplies: heavy cream
jar or churn
salt
butter mold

Set the cream out to warm for 12 hours before churning, it is then called clabbered cream. Place heavy cream in jar or churn and shake until the butter is separated from the buttermilk. Lift butter out of container and place in a bowl. Rinse the butter with water and stir in salt. Place in butter molds.

HAND-DIPPED CANDLES

Place parafin, candle dye (crayons can be used), and scented oil (optional) in a #8 size can. Take a #10 size can and punch two holes opposite from each other near the top of the can. Insert picture wire in the holes to create a handle.

Put the #8 size can with the wax into the #10 can. Fill the #10 can $\frac{3}{4}$ full with water, and place on top of a stove or fire. Heat the wax in the makeshift fouble-boiler until it is completely melted. Remove from heat.

Fill a container with water and place it a couple of feet from the melted wax. Candle dipping should be done outside or in an area that is covered with newspaper. Tie 9-inches of candle wick to a stick, then dip first into the wax then into the cold water. Clothes drying racks, with numbered pinch type clothes pins, to hold candles, help to identify individuals candles after they have cooled. Allow candles to hang on stick until wax is totally cooled (approximately 1 hour).



Candle dipping is enjoyed by participants of all ages and provides the participant with a useful end product.

JUG BAND INSTRUMENTSHelpful Supplies:

combs	pebbles
wax paper	sand
wood blocks	jug
sandpaper	washboard
flower pots	spoons
tin cans	sticks
oatmeal	washtub
containers	rocks
bells	thimbles

Finishing Supplies:

stapler	glue
tape	construction
markers	paper
scissors	

Instrument Preparation Ideas:

1. comb & wax paper-fold wax paper over comb, hum against teeth edge of comb to make noise
2. woodblocks & sandpaper-fasten sandpaper to block and rub together for noise
3. container with lid and rock/pebble/sand-put items inside, cover and decorate container, then shake for noise
4. jug-decorate and blow across opening for noise
5. washboard and thimbles/sticks/spoons-rub item across washboard to make noise
6. flower pot/container-use like drum
7. spoons-clap together for noise
8. bells-shake for noise
9. rhythm sticks-beat together for noise

CORNBREAD RECIPE

Ingredients: 2 c. cornmeal
1 c. flour
1 c. buttermilk
1 Tlb. baking soda
1 tsp. salt

Equipment: dutch oven or heavy pan
foil

Line dutch oven with foil. Heat pot and lid on fire with pork rind in it. After heated, run rind around pot so it is greasy.

Sprinkle cornmeal on sides of pot, pour batter, cover, cook 15-20 minutes, turning bread when bottom is golden brown to cook even (or fill inverted lid of dutch oven with red hot coals).

For variation add blueberries, strawberries or other fruits.

COUNTRY STYLE VANILLA ICE CREAM WITH PEPPERMINT

2 eggs	1/4 c. sugar
2 1/2 c. milk	2 c. half/half
1 tlbsp. vanilla	1/8 tsp. salt

In a large bowl beat eggs til foamy. Slowly add sugar and beat until thickened. Add cream, vanilla, salt and mix completely. Pour into a can. Add milk to "fill-line" on can and stir well. Put can in ice cream freezer, put in paddles and close lid. Attach handle. Layer ice and salt to top. Add 1 cup of cold water to ice/salt mixture. Start cranking! Should take about 20 minutes. Add peppermint chips when just about solid. (Makes 2 quarts)

MAKING PAPERSupplies:

egg beater	newspaper
large pot	water
screening	iron
manilla paper	bleach
coat hangers	

To begin, tear up several sheets of newspaper into very tiny pieces. Put these into the pot and add enough water to allow the paper pieces to float. Add a small amount of bleach to remove discoloration of the ink. Beat well with the egg beater. This mixture is called slurry.

Cut the screening into 8" squares. Form the coat hangers into a 7" square frame with a handle. Attach the screening to this frame. Dip the screen into the slurry, raising it up slowly so the water will drain off.

Blot the screen on top of a sheet of manilla paper placed between a thick section of newspaper. Press with a warm, not hot, iron until dry.

Be careful not to use pans or beaters that will be used in the future for food preparations.

CORN HUSK DOLLSSupplies:

corn husks	scissors
glycerine	large bucket
string (med.)	water

Preparing the Corn Husks:

Corn husks are generally worked damp (not wet but damp). Place the dried husks in a large bucket of water with a small amount of glycerine (2 tsp. to every gallon of water). Allow the corn husks to soak for 20 minutes. After they have softened, remove them and shake off the excess water. Wrap them in a damp cloth or towel until ready to work. If the corn husks should dry out, simply resoak them.

Making the Dolls:

Use a section of 8 or more connected corn husks for the main body. Tie off a section 2" from the connecting point to form the head. Braid an 8" segment and insert below this for the arms. Tie off and trim each end of the arms. Tie tightly below the arms to hold into place. To form the legs, divide the remaining portion of the corn husk body and tie off the two legs. Trim below the string. Use additional corn husks to fashion dress, hair, vest, etc. Imagination and creativity will determine the sophistication of the doll.

CREATING PIONEER TOYSDancing ManSupplies:

3/4" thick wood for man's body
 1/4" thick wood for man's arms
 4" wide by 1' long of thin wood
 (balsa) for dancing board
 1' of 1/4" dowl rod for handle
 white glue
 wire
 sand paper

Equipment:

hand saw	wire cutter
hand drill and bit	vice grips
pliers	cardboard
	pattern of body pieces

Instructions:

1. Cut out pattern of body pieces
2. Trace pattern onto wood
3. Cut out body pieces, drill and sand
4. Cut up wire into 6 1" pieces
5. Assemble man using the wire to attach the limbs loosely to the body
6. Trim wire so there are no sharp ends
7. Drill hole into back deep enough to insert the dowl handle
8. Attach the dowl into the hole with glue

After the glue has dried, place dancing board under one leg to secure it. Stand dancing man on the other end of the dancing board holding the end of the handle. Dance the man by tapping on the dancing board and moving the handle enough to jiggle his feet.

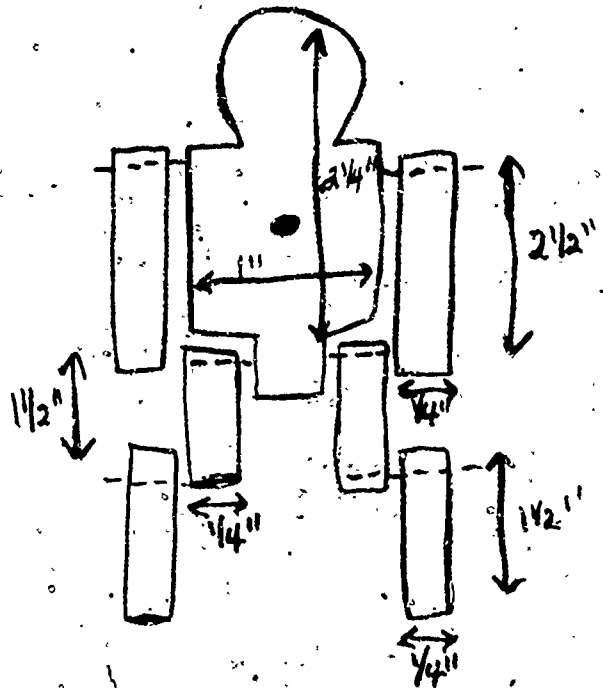

Whimmy DiddleSupplies:

8" of 3/8" dowel rod
 4" of 3/8" dowel rod
 sand paper
 1 1/2" of 3/16" dowel rod
 1" finishing tack

Equipment:

hand saw hand drill, bit
 coping saw vice grips
 or hammer
 angled wood file

Instructions:

1. Carve out middle area of roter to concentrate weight at ends.
2. Carve 6 to 10 notches about 1/8" deep evenly spaced on the top of the body and rubbing stick.

3. Place roter into vice grips and drill a hole smaller than the head of tack.
4. Place body into the vice grip and hammer the roter onto the end of the body with the finishing tack.

Rub the rubbing stick against the notches in the body to rotate the roter. Try to make the roter stop and move in the other direction by rubbing with the thumb nail flush against the body.

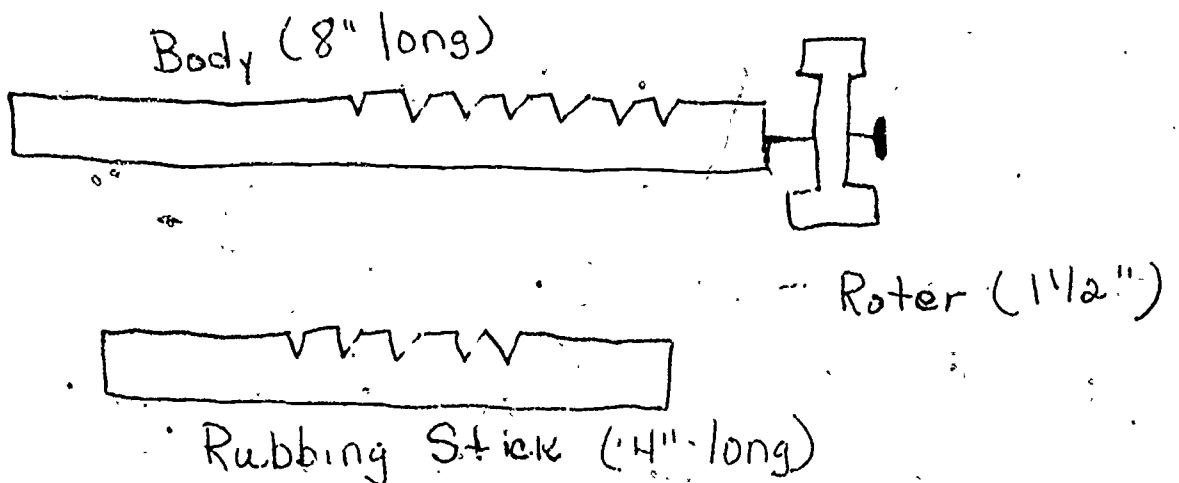

Buzz SawSupplies:

2 3/4" diameter by 1/2" thick disk of hardwood
 2 3" sections of 1/2" dowel or tree branch
 40" segment of heavy cord
 sand paper

Equipment:

hand saw scissors
 hand drill/bit vice grips
 cardboard pattern

Instructions:

1. Use pattern to mark holes to be drilled on the disk.
2. Drill holes in disk and sand.

3. Mark holes to be drilled in the handles.
4. Place in vice grips and drill.
5. Sand the handles.
6. Assemble the pieces onto the string (see diagram) and tie the string together into a knot forming a loop.

Hold one handle in each hand. Wind the disk up until the string is tight. Pull back on the handles forcing the disk to rotate and make a buzzing sound.

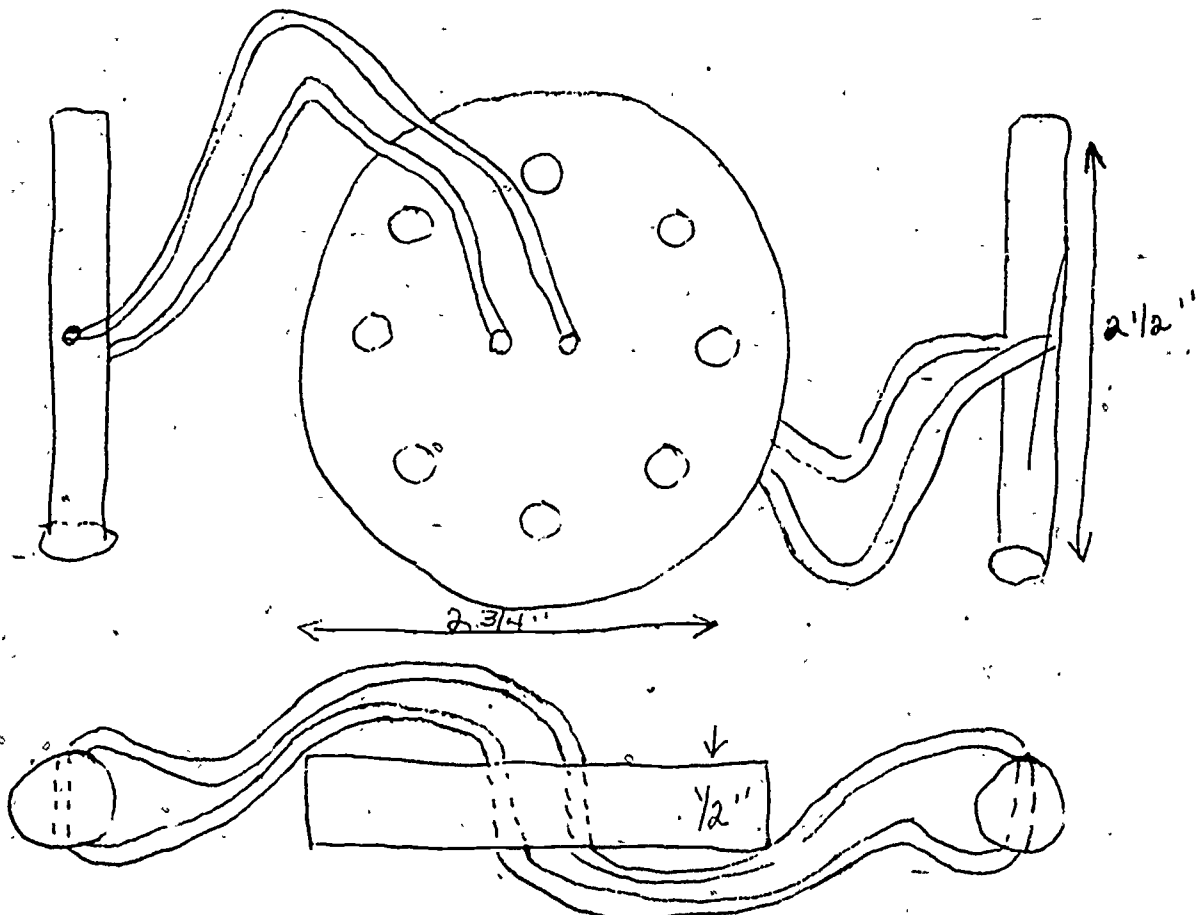

- To Assemble:
1. String through hole in #1 handle
 2. String through center holes in disk
 3. String through hole in #2 handle
 4. Knot ends

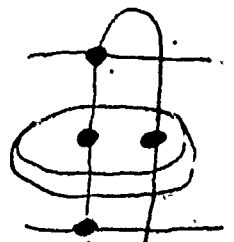

REFERENCES

- A Collection of Dances of Children (card file). Marie Vick and Rosann McLaughlin Cox, Burgess Publishing Co., Minneapolis, Minn., 1970.
- American Folk Tales and Songs. Richard Chase, Dover Publications, Inc., N. Y., 1974.
- American Folklore. Life ed., Time, Inc., N. Y., 1961.
- Basic Baskets. Mara Cary, Houghton Mifflin Co., Boston, 1975.
- Better Homes & Gardens Heritage Cook Book. Editors of Better Homes & Gardens, Meridith Co., 1975.
- Corn-Husk Crafts. Margery Facklam and Patricia Phibbs, Sterling Publishing Co., Inc., N. Y., 1973.
- Country Scrapbook. Jerry Mack Johnson, Doubleday and Co., Inc., N. Y., 1974.
- Eating In America: A History. Wasnesly Root and Richard Rockemont.
- Foxfire 1, 2, 3, 4, 5, and 6. Edited by Eliot Wigginton, Anchor Press/Doubleday, Garden City, N. Y.
- How to Make Corn-Husk Dolls. Ruth Wendorff, Arco Publishing Co., Inc., N. Y., 1973.
- "Like It Was" Bicentennial Games 'N Fun Handbook. Adah Parker Strobell, Acropolis Books Ltd., Washington, D. C., 1975.
- Naturally Powered Old Time Toys. Majorie Henderson and Elizabeth Wilkinson, J. B. Lippencott Co., N. Y., 1978.
- Spinning and Dyeing the Natural Way. Ruth Castino, Van Nostrand Reinhold Co., N. Y., 1974.
- The American Heritage Cook Book. Editors of American Heritage Magazine.
- The Golden Book of Colonial Crafts. Golden Press, N. Y., 1975.
- The Rhythm Band Book. Ruth Etkin, Sterling Publishing Co., N. Y., 1978.
- Vegetable Dyeing, 151 color recipies for dyeing yarns and fabrics with natural materials. Alma Lesch, Watson-Guptill Publications, N. Y., 1970.
- Books by Eric Sloane, Ballantine Books, N. Y., N. Y. Samples: A Reference for Wood, Age of Barns, Diary of an Early American Boy, America Yesterday, I Remembered America, and many more.
- Also check "Country Life" or "Handicrafts" at library.

A NEW WAY OF LOOKING AT ORIENTEERING: MODIFYING WHEELCHAIRS FOR COMPASS USE

THOMAS E. BARHAM
BRADFORD WOODS OUTDOOR EDUCATION CENTER
MARTINSVILLE, INDIANA

INTRODUCTION

Many camps across the country offer a wide variety of map and compass related activities. The range of these activities vary as much as those who participate in them. From a week long fifty-mile trek across the rugged terrain of the Colorado Rockies, requiring sophisticated skill in use of both map and compass, to teaching a child with a learning disability which direction the sun sets and rises.

However, with reference to individuals who utilize wheelchairs as their primary mode of mobility, special problems arise. This is not to say that certain map-use problems do not exist, but rather to point out that of the two items used, the compass presents special modification problems which may be more difficult to solve than those related to use of the map.

For all purposes and intent of this paper, orienteering will be defined simply as the combined use of compass and map skills to find ones way. However, the uniqueness of the individuals served will determine program approach (Morisbak, 1981) and thus necessitate change in this definition.

It is not the intent of this paper to "teach" orienteering, but to demonstrate the potential use of a device designed to modify wheelchairs in a manner conducive to the instruction and use of the compass. Nevertheless, learning to use the orienteering compass (Kjellstrom, 1975) is not difficult and requires little time. In fact, the Type 7NL Silva compass comes with an easy-to-understand instruction sheet which simplifies the learning process to the point of fun.

Modifying wheelchairs for the aforementioned purposes suggests either developing new methodologies for teaching orienteering or altering current ones. The latter, of course, would appear to be the most "preferred" approach.

The intent of this paper is to: (1) explore programatic and educational potential via utilization of the device, (2) suggest some specifics regarding ways of altering current compass-related instructional materials, (3) communicate the information and process necessary to construct the device, (4) survey the strengths and weaknesses of the device, and (5) provide informational

resource list to aid others in beginning a new program or altering an existing program.

WHO CAN USE THIS DEVICE?

In its current state of development the device is usable by:

- those who have the ability to mobilize themselves
- those who may be mobilized with assistance
- persons who are sighted

PROGRAMATIC AND EDUCATIONAL POTENTIAL

Programatic:

- adding another program component requiring minimal cost and little space
- utilization of currently existing compass instructional aids
- persons who are disabled can practice map and compass skills independently and effectively
- persons who are disabled can teach via this method
- the device may be used in or out-of-doors

Educational:

- teaching the proper use of map and compass per se
- encouraging environmental awareness by bringing the individual in closer contact with the natural environment

Example:

- Key compass course to:
 1. identification trails (trees, flowers, etc.)
 2. Sensory trails (describe what objects feel, smell, taste, look and sound like)

3. Scavenger Hunt (distribute a list of natural objects to be found)
4. A-B-C Hike (the name of each natural object found is listed beside the letter which begins the word, until all letters in the alphabet are represented)
5. Poetry Hike (observe surrounding at pre-determined sites and write a different style of poetry at each); integrate art into this scheme

-Encourage Problem Solving:

Example:

1. Develop tasks stations which possess graduated degrees of difficulty to challenge the participant.

-Teaching Mathematical Concepts:

Example:

1. Addition, division and subtraction necessary to figuring individual pace with the wheelchair.
2. Utilizing the wheelchair as a unit of measurement.
3. Transferring compass degrees from the ground to a map and vice-versa.
4. Judging distances.

-Encouraging healthful living through physical activity.

-Enhancing self-concept by providing an activity through which success may be realized independently or as a group.

-Introducing an activity which may stimulate a life-time of interest and participation.

Perhaps the preceding list will stimulate creative thinking and encourage exploration of more ideas which may be integrated into a compass/map related activity.

STRENGTHS AND WEAKNESSES OF THE DEVICE

STRENGTHS:

1. The same principles applied to teaching map/compass and orienteering skills to able-bodied persons may also be applied to persons who are disabled. Thus, currently existing instructional materials may be utilized.
2. The device is designed so users may independently attach and remove it from a wheelchair.
3. It can be used to convey outdoor educational/ environmental awareness concepts, recreational and physical educational activities and the enhancement of socialization through group efforts.
4. The device may be used in or out-of-doors.
5. The device is not difficult to build. Your "in-house" scrap pile will yield most of the materials needed for construction.
6. The device is relatively small and may be assembled and dismantled with ease, and requires little or no maintenance.
7. It is not necessary for the participant to "stop" and pick the compass up in order to "set" it on a given bearing.
8. After the compass has been set on a given bearing it again is not necessary to pick the compass up to properly "orient" oneself to the ground. Simply turn the wheelchair while watching the compass needle until the needle is properly aligned. This allows greater mobility and accuracy since it would be difficult, if not impossible in some cases, to hold and properly orient the compass while trying to turn the wheels of a chair.
9. The sighting rods allow greater accuracy than would be achieved by picking the compass up and attempting to "eyeball" an object or point which falls in line with the compass needle, or direction of travel arrow. This is especially applicable if the participant has the dexterity to turn the wheels of a chair, but not to hold a small object such as a compass.

WEAKNESSES

1. The current state of development limits use of the device to persons who have varying degrees of dexterity/mobility.
2. Due to the necessity of individualizing the design of the device to each participant, more time will be required to construct a large number of the devices since a "standardized" design format may not be possible.

3. Due to design, metallic composition, or a combination of the two, each wheelchair may reflect PLUS or MINUS degree compass readings compared to actual degrees from one point to another. For example, actual degrees from a tree to a stump may be 20. However, due to the "degree variance factor" the compass (attached to the device resting on the chair arms) may show 15 PLUS or MINUS degrees (i.e., 45 or 15 degrees respectively). This situation can be partially resolved by determining what the "variance factor" is for each wheelchair and making corrections accordingly. For example, if the "variance factor" for a chair is PLUS 10 degrees, then 10 degrees would be subtracted from whatever reading the compass reflected while attached to that particular wheelchair. Also, in testing, some wheelchairs reflected no variance either way. I must emphasize that the distraction of the compass needle by the metallic substances inherent in current wheelchair design remains a major problem with the device. Until this problem is resolved through design, the "variance factor" computation may be integrated with varying degrees of success (depending on the wheelchair) into existing compass instructional materials.

ORIENTEERING DEVICE ADAPTABLE TO WHEELCHAIRS (See photo and Diagram "A")



1. Baseboard. The base or "platform" is affixed to the wheelchair and supports all components of the device. The baseboard may be affixed with 1/4 inch cords or velcro, which is either glued or taped (some velcro has a self-adhesive backing) to bottom of the baseboard and arms of the wheelchair.

2. Wooden Directional Sighting Rods. This feature "raises" the alignment plane to a point relatively level with the sighting plane of the participant. The two wooden dowels are, in effect used like the sights on a rifle. Once the compass is "set" the participant then has free use of the hands to orient himself to a specific point while in the chair, and with minimal effort.
3. Wooden Directional Pointer. The directional pointer supports one of the two sighting rods and the compass. The pointer may be designed to pivot (see Diagram "B") or it may be permanently affixed to the baseboard. If the pointer is designed to pivot one has the added advantage of the ability to visually orient oneself before turning the wheelchair to achieve actual orientation to the ground. This serves as a "quick" reference technique which may be valuable when timed orienteering is conducted.
4. Reference Lines. These represent a continuous straight line through all parts of the device and serve to facilitate accuracy in alignment and sighting on objects. Thin strips of reflector tape (use a bright color) glued to the wooden directional pointer and front and back of the baseboard serve this purpose. The direction of travel arrow of the compass should be aligned with the reference lines on the directional pointer.
5. Silva Compass-Type 7NL. The compass is fit into a slot cut into the back portion of the directional pointer (Diagram "B"). The compass can be easily seen and manipulated from this position, and does not require removal to operate the compass housing. However, no problem is posed should removal of the compass become necessary. Simply slit it in and out of the slot. Removal may be further simplified by affixing the compass to the directional pointer with self-adhering velcro tape.
6. 1/4 Inch Holes. Four sets of two (2) holes will be required. The two holes closest to the outside of the board are to be extended to the edge of the board to form a "notch". Through each set of these holes an 18 inch piece of nylon cord is threaded and tied to either the underside of the wheelchair arms, or to the top of the baseboard. Also, a series of 3, 4 or 5 holes may be drilled which will allow the same baseboard to be used on wheelchairs with varying distances between the arms.

DIAGRAM A

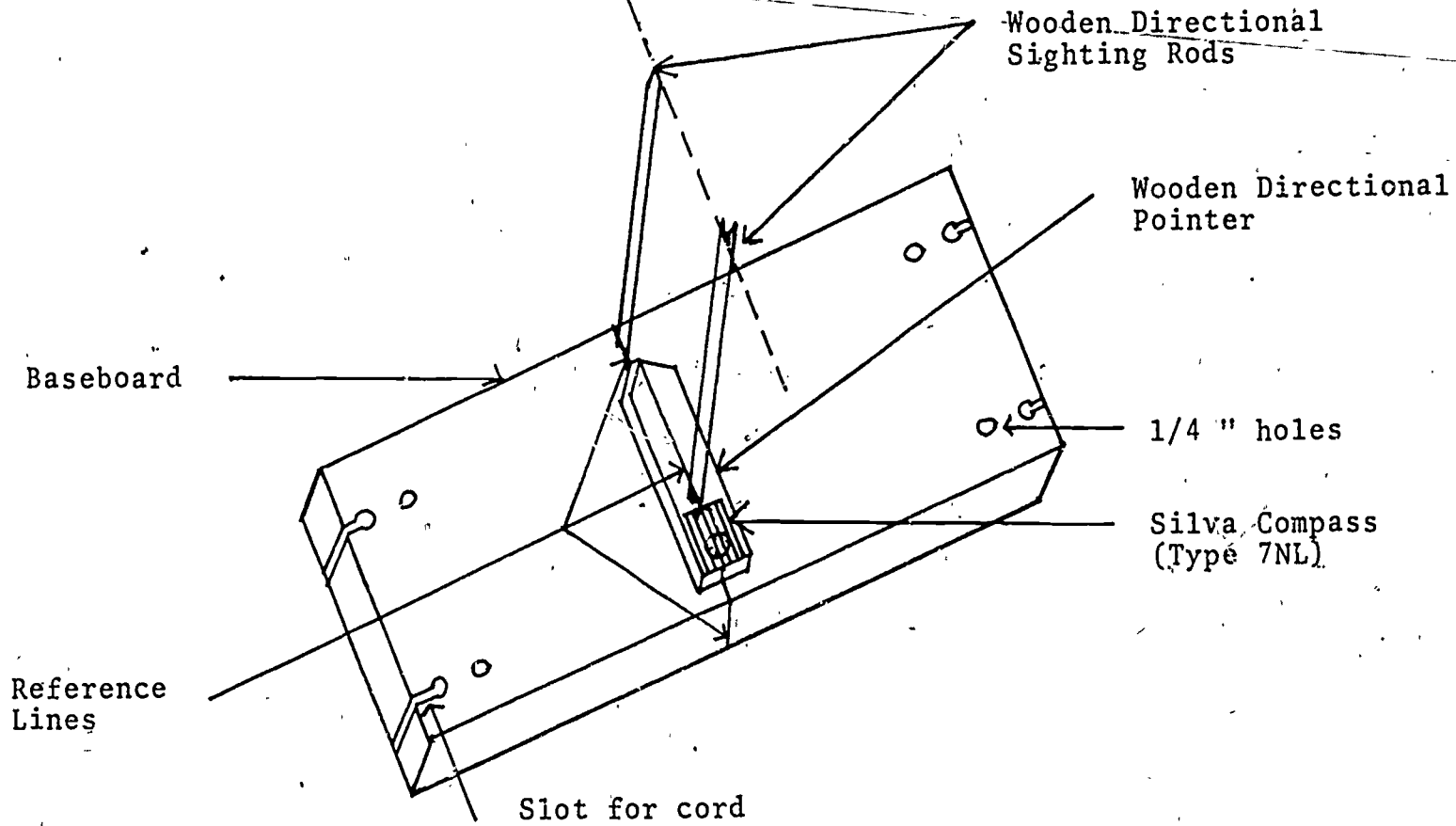

DIAGRAM A

86

93

ORIENTEERING DEVICE ADAPTABLE TO WHEELCHAIRS

92

DESIGN INSTRUCTIONS

(Diagram "B")

1. The actual width and length of the baseboard will depend on the size and design of the wheelchair. Be sure to take measurement before beginning any work. This device is designed for wheelchairs with arms.
2. It's important that the wooden directional pointer be mounted so it is in direct line with the reference lines which run from the front to the back of the baseboard.
3. The tip front portion of the sighting device (i.e., dowel rod) should be "sharpened" to a blunt point and painted red or white. Discarded target arrows have a notch on one end and a blunt metallic tip on the other and thus serve the same function as the wooden dowels. The metal end of the target arrow is displaced far enough from the compass that "distracting" the compass needle does not become a problem. If a wooden rod is used for the rear portion of the sighting device (instead of using a target arrow), then the dowel will need to be notched.
4. The Silva compass is fit into a notch cut in the rear of the wooden directional pointer. The wooden pointer, and the remainder of the device (baseboard and sighting rods), should be painted flat black. The paint protects the wood and the black allows objects to be seen with greater ease.
5. When using 1/4" wooden dowel rods for the sighting rods, drill 15/16" holes so the dowels fit snugly when fixed into place. When using target arrows for sighting rods the dimensions for a snug fit will be different.
6. Although the wooden directional pointer is designed to pivot, it may also be permanently affixed by gluing it in place.
7. Masking or electricians tape may be used for the pace indicator (Diagram "C") which is attached to one wheel of the wheelchair. It must be wrapped thickly so it can be felt with the hand or fingers with each turn of the wheel. If determining wheel revolutions by sight, simply paint the masking tape a bright color.

DIAGRAM B

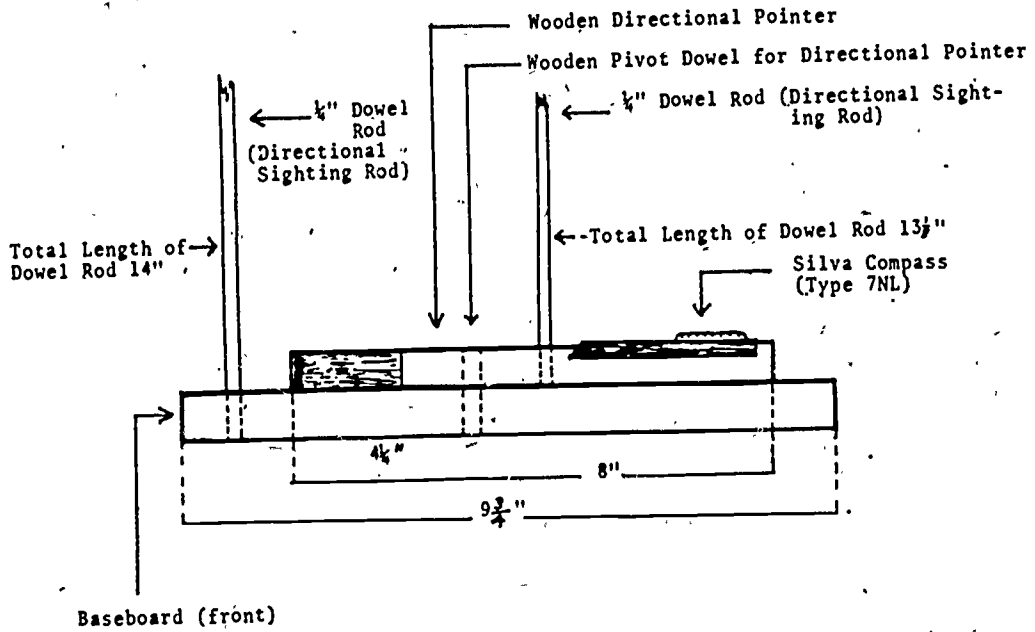

SIDE VIEW OF ORIENTEERING DEVICE

DIAGRAM C

SIDE VIEW OF ORIENTEERING DEVICE AND PACE INDICATOR ATTACHED TO WHEELCHAIR

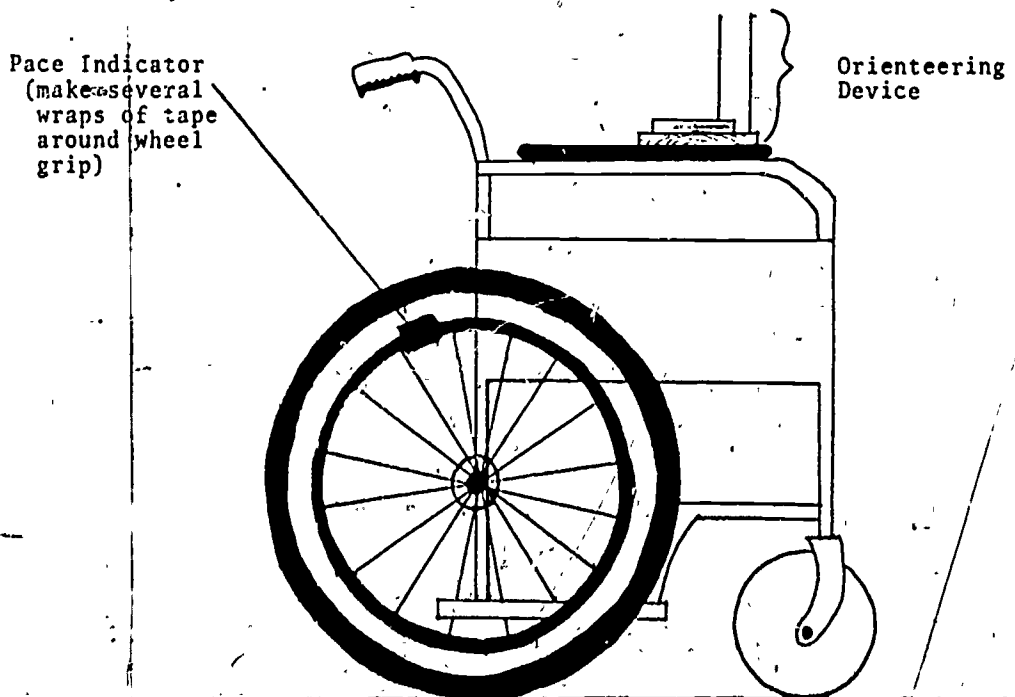

MATERIALS AND COST ESTIMATESMaterials:

- 1 piece of 1/4" dowel rod
3' long Cost: .51¢
- 1 piece of 1/2" thick
plywood (or pine) 2' long
X 9 3/4" wide Cost: \$1.50
- 1 piece of pine 2" wide X 8"
long X 3/4" to 1" thick
Cost: .50¢
- 4 pieces of 1/8" nylon cord
18" long Cost: \$1.00
- 1 roll of masking or
electricians tape (masking
tape is cheaper)
Cost: .50-\$1.00
- 1 Silva compass-Type 7NL
(see references) Cost: \$6.25
- 4' velcro tape @ .95¢ per foot
Cost \$3.95
- 1 can of flat black paint
(spray can is more expensive)
Cost: .75-\$1.25

NOTE: Scrounge before you spend bucks. Many of the aforementioned items can probably be found in or around your maintenance building.

DIMENSIONS (Diagrams "A" & "B")

The following dimensions apply to the particular device constructed for demonstration purposes. Actual dimensions of other devices may vary, depending on:

- type of wheelchair used
(e.g., type of arms and height of chair, etc.)
- size of participant (e.g., how high they sit in chair)
- physical dexterity and mobility of participant

General Dimensions (Diagram "A")

1. Baseboard. 9 3/4" wide
X 2' long X 1/2" to 3/4"
thick.

2. Wooden Directional Sighting Rods. two
1/4" wooden dowel rods
(when 1/4" dowels-drill
15/16" holes)

3. Wooden Directional Pointer. 2" wide X 8"
long X 3/4" thick.

4. 1/4" Holes. four sets
of two holes drilled to
accomodate 1/3" cords.
Distance between each
hole will vary, depending
on width of wheelchair
arm pad.

Specific Dimensions (Diagram "B")

Dimensions shown in this diagram reflect those of an actual demonstrator model and should NOT be considered a "standardized" format.

MODIFIED PACE INDICATOR
(Diagram "C")

The pace indicator is used in determining the distance traveled for every revolution of the wheels. This allows one to utilize the wheelchair as a unit of measurement for orienteering, and perhaps for other reasons.

The actual pace for each wheelchair may be different, just as each person's individual step will be different, depending on the size of the wheels.

Equipment Needed To Set Up
Pace Course

- an area of relatively level
ground (6% slope, or less).
100 feet long, or 100 feet
of cement walkway or
blacktop surface.

- two wooden stakes approximately 18" long and sharpened on one end.
- 100 foot measuring tape.
- Silva compass with 100 feet of string.
- hammer to set stakes in ground.

Instructions For Setting Up Pace Course

- first measure a line 100 feet in length.
- drive a stake at each end of the line.
- tie the string to each stake so the person going through the course will remain on a straight line.
- if using a sidewalk area simply place the stakes along the sidewalk 100 feet apart, or paint/tape a line at each end of the 100 foot marks.

PACING INSTRUCTIONS

- a) Position the tape pace indicator (Diagram "C") so it is even with one of the stakes and located at the closest point to the ground. This insures that the wheel will make one full revolution at the beginning of the course.
- b) Begin rolling the chair by feeling the pace indicator, or by vision, count the number of wheel turns it takes to travel through the 100 foot course.
- c) Pace Figuring Card (Diagram "D"). To determine the distance for each revolution of the wheel, roll two times through the 100 foot course. On the

pace figuring card record the number of wheel revolutions counted each time through the course. Add these two figures and enter them on line (A). Enter on line (B) the total number of feet (or meters) traveled during the two trip through the course. Finally, divide line (B) by line (A) and enter the product on line (C). The final number appearing on line (C) will equal the number of feet traveled for each revolution.

- d) A clicking device may be attached to some types of wheelchairs as an alternative method for counting wheel revolutions.

DIAGRAM "D"

PACE FIGURING CARD

Number of revolutions first time _____
 Number of revolutions second time _____
 Total Revolutions _____ (A)
 Total number of feet (or meters) in distance rolled _____ (B)

(B)	(A)	(C)
Total Distance Rolled	Total Revolutions Taken	Number of Feet (or meters) in Each Revolution

MODIFYING EXISTING
INSTRUCTIONAL MATERIALS

There exists on the market today a wide array of compass, map and orienteering related instructional materials. The following represent examples of modifying two specific compass games which have proven very effective in teaching the basics of compass use.

The compass games discussed, if purchased, should be keyed with the following respective narratives.

1. Silva Beginner's Compass Course - A Circular Course (Silva Compass Game-see references)

Modifying Variables

- a) cardboard panels to replace wooden stakes (Diagram "E"). The panels allow greater location versatility of the game.

2. Silva Compass Game in Feet-A Linear Game, also available in meters (Silva Compass Game in Feet-see references)

Modifying Variables

- a) drive wooden stakes along a smooth surfaced road or sidewalk-must be on an EAST/WEST line
- b) modify pacing instructions (see Diagram "C")
- c) eliminate wooden stakes for compass game (Kjellstrom, 1975); use string and cloth
- d) paint or tape numbers on sidewalk or blacktop surface in place of wooden stakes-must be on an EAST/WEST line

Location Modifications For Above Courses:

Each of the above courses may be assembled and effectively executed in the following locations. Regardless of the location, be aware that

DIAGRAM E

PANEL MATERIAL: heavy cardboard

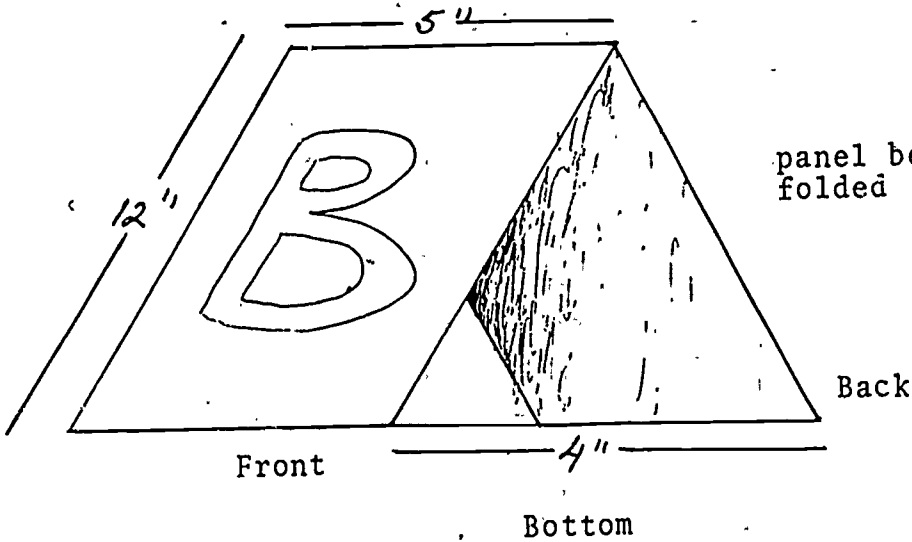

Dimensions (panel before folded)

panel before folded

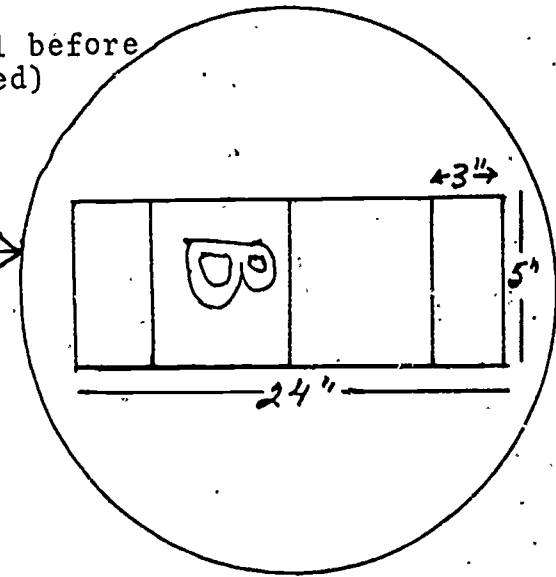

DIAGRAM E

92

PANEL DESIGN FOR CIRCULAR COMPASS COURSE

side view of folded panel

brick weight to hold firmly to ground

overlap two sections of panel bottoms & staple

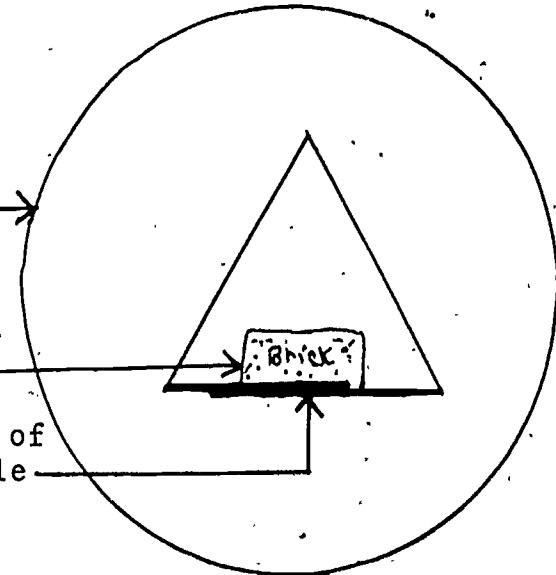

100

NOTE

spray panels with silicone to help waterproof

99

un-seen metallic objects/ structures may effect the compass needle (e.g., underground pipes, metal beams, etc.):

- parking lots
- parks; gymnasiums
- school or hospital grounds
- any large area in which there are objects to affix orienteering course or compass game markers
- indoors (affix markers to chairs, tables, etc.)
 - .dining halls; gymnasium;
 - activity center
 - .classroom

MODIFYING AN ORIENTEERING COURSE

There is no "secret" to this, other than knowing and responding in accordance with the needs of the prospective participants. In general, when working with persons who utilize wheelchairs:

- a) select a relatively level surface (depending on the desired difficulty level of the course) of 6% slope, or less
- b) be sure control point markers are placed so they are both visible and accessible from a wheelchair
- c) get in a wheelchair and field test the course before implementing

SOME THOUGHTS ON MODIFYING

The possibilities for modifying other compass, map and orienteering related instructional materials is virtually limitless. First, you need to decide on exactly what you want to do (e.g., teach the basics of map/compass, set up a competition course, convey education/environmental

concepts, etc.). Second, select and analyze materials related to your idea and how these materials might be integrated into a compass, map or orienteering related activity. Third, based on the resources at hand (human and material) decide on which variables you can realistically and effectively manipulate. Fourth, collect the materials needed (don't forget to scrounge before spending bucks) and go to work. Fifth, check all work for safety. Sixth, field test that which has been modified before implementing it into a program. Solicit the opinions and ideas of others when possible. Lastly, evaluate the effectiveness of the modified product (i.e., course, materials, device, etc.).

IDEAS-SUGGESTIONS-CONSTRUCTIVE CRITICISMS.

The following thoughts were offered by individuals attending a presentation given on the modifying device addressed in this paper during the Third Annual Institute On Innovations In Camping and Outdoor Education With Persons Who Are Disabled:

1. Eliminate the sighting rods (too dangerous) and extend the length of the wooden directional pointer.
2. Build a sliding mechanism so the compass can be moved left or right to accommodate an individual who cannot move or raise their head.

3. Use the wooden directional pointer separate from the rest of the device to teach compass to able-bodied persons. Reason? Because the directional pointer represents an increased extension of the direction of travel arrow on the compass, thus making it easier to sight on an object.
4. Use velcro to attach device to wheelchairs. Reason? Simplifies attachment and removal for the participant and facilitates quick removal for safety reasons.

EDITORS NOTE: Mr. Thomas Barham is the designer and constructor of the device described in this article. For further information readers are urged to contact him at Bradford Woods, 5040 State Road 67 N.; Martinsville, Indiana 40151. Phone (317) 342-2915.

Silva Beginner Compass Course, (circular course), Silva Company, 2466 State Road 39 N., La Porte, Indiana, 46350, available through American Camping Assoc., \$2.00 - 1982 price.

Silva Compass - Type 7NL, Silva Company, Box 1604, Birmingham, N. Y., 13902, available through American Camping Assoc., \$6.25-1982 price.

Silva Compass Game, (a linear course in feet or meters), Silva Company, 2466 State Road 39 N., La Porte, Indiana, 46350, available through American Camping Assoc., 5049 State Road 67 N., Martinsville, Indiana, 46151, \$1.85-1982 price.

REFERENCES

Kjellstrom, Bjorn, Be Expert With Map and Compass: The "Orienteering" Handbook (Revised Edition), Charles Scribner's Sons, New York, 1975.

Morisbak, Inge, Orienteering: What It Is and How It Can Be Provided As An Activity For Handicappers, The Bradford Papers, Vol. 11, 1982, pp. 79-85.

REMOVING BARRIERS TO THE BARRIERS

A NEW ADAPTED ROPES COURSE

KIRK B. WEAVER
COLUMBIA, MISSOURI

EDITOR'S NOTE: This article is intended for descriptive purposes only and NOT for design, construction or leadership purposes. All ropes courses require extensive orientation and training and must be designed and built by experts. For further details on including a similar course in your program, readers are encouraged to contact the editor.

More and more educators are using the outdoors as an alternative learning environment. The outdoor classroom is a unique and stimulating learning environment and within this environment, an increasingly popular "textbook" being used is the ropes course. Simply stated, a ropes course is a series of barriers or elements to be overcome by the participant. In the past, course accessibility and element design inhibited involvement by persons with disabilities.

Bradford Woods, a laboratory for outdoor learning, has maintained its own ropes course since 1975. The course following traditional design, is consequently, difficult for physically disabled participants to reach. In 1982 Bradford Woods constructed a new ropes course so that disabled and able bodied alike can share the benefits of a ropes course experience.

Although adapted for the disabled, it was discovered that design changes not only increased accessibility but added new challenge for able bodied participants. The course consists of ten elements layed out in a circular,

continuous format. Seven additional elements form an alternative loop connected to the main course. This paper will focus on the ten main elements although it should be noted at the outset that completion of all ten elements is not essential to its use. Instead, elements are matched to the individual needs of each participant.

There are three main facets to the adapted ropes course philosophy: (1)safety; (2) fun; and (3) therapy.

SAFETY

Safety is the first priority. Risk is an important aspect of adventure yet adventure need not be dangerous. Safety lines are used on all higher elements, and a team of spotters follow established safety procedures as they guide each participant through the elements. While danger is minimized, creativity is maximized and participants are encouraged to determine the best way for them, through the elements. The primary role is that when creativity clashes with safety, safety remains the first priority.



FUN

Children and adults enjoy testing their abilities on the ropes course. The experience should push personal limits but not to the point where it ceases to be fun. Some enjoy themselves during the challenge while others feel the joy only after the element is completed. Spotters are trained to step in when frustration begins to turn a positive challenge into a negative memory.

THERAPY

When safety and fun are established, therapy can take place. Without the first two facets the individual would not be on the course. The potential for therapeutic benefit are many. Factors such as coordination, balance, and attentiveness are built into the course design. Elements can be further individualized to meet participant's needs by using designed variations and spotter assistance. Several of these benefits will be discussed in detail.

Confidence is one of therapeutic benefits. The person with a disability is confronted with barriers everyday: barriers which threaten to inhibit involvement and independence. The adapted ropes course places the participant in an environment where obstacles are fun and present a positive challenge. Participants push personal limits and overcome seemingly impossible obstacles which breeds a

feeling of accomplishment and increases self-confidence. Success breeds success. Obstacles become opportunities!

Physical development is a second benefit. The amount of body strength and control required for completion varies throughout the ten elements. Several elements emphasize upper body strength, some emphasize lower body coordination, and still others challenge mental handicaps or emotional blocks such as fear and mistrust. The strong upper body strength of persons with lower extremity impairments, and the coordination required to advance a wheelchair evenly are purposefully matched in certain elements of the course.

All participants benefit from an increased understanding of each others special strengths. A group bond is formed as spectators encourage participants. For the disabled participant a traditional ropes course design requires completion on able bodied terms, while sharing experiences as they conquer the elements.

Incorporating academic learning into the ropes course is another benefit. The elements present life size object lessons. Terms like over, under, around, and through are experienced by the participant. One elementary student practiced his addition and subtraction as he passed through the swinging tires by tracking how many were left and how many he had passed.

Cognitive issues such as strategy, planning ahead, and creativity are encouraged and necessary to complete the elements. Consequences of decisions are immediate and real.

All ten elements in the main loop can be completed by non-ambulatory participants. Several of the elements in the alternative loop require ambulatory skills. For this reason only the ten main elements will be discussed in detail.

INCLINED BALANCE BEAM (see Sketch, #1)

In this element the participant moves along two parallel beams to an elevated platform. Participants are encouraged to ride a wheelchair along the beams, however, for some, the challenge of walking up the beam-ramp is more appropriate. Each beam is comprised of three sections two of which are removable to vary the challenge by reducing or increasing the beam width.

A special benefit for ambulatory participants is an increased understanding and empathy for non-ambulatory friends. For non-ambulatory participants the element incorporates a familiar skill allowing them to use and test strength, coordination and trust.



The Inclined Balance Beam provides test of strength, agility, and coordination.

CARGO NET (see Sketch #1)

The Cargo Net is a fifteen by four foot interwoven rectangle of webbing suspended off the ground. The base of the net hangs beside the Inclined Balance Beam platform (about three feet off the ground) while the top of the net attaches to an elevated tree platform approximately five feet high. Traditionally, rope is used in making a cargo net, however, in this case webbing was substituted to minimize abrasions.

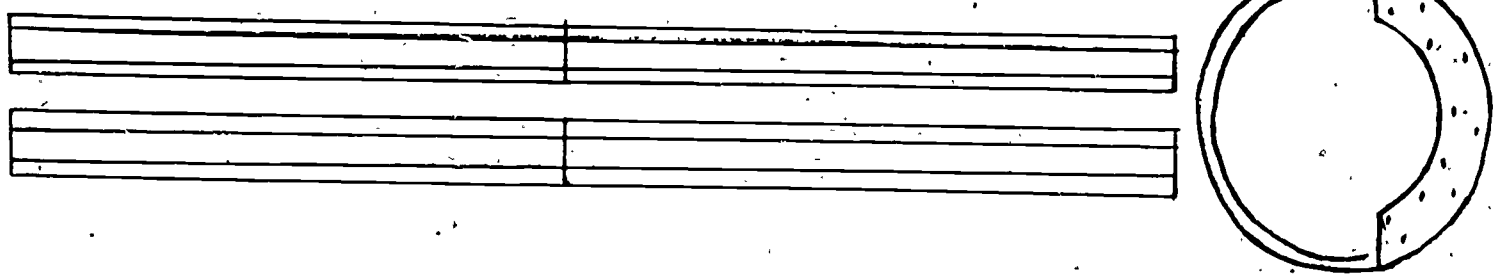

INCLINED BALANCE BEAM

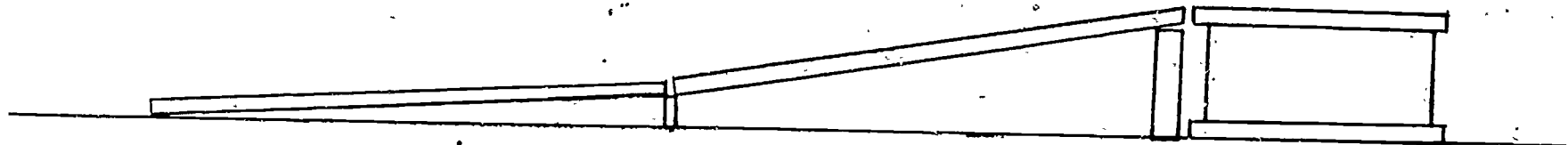

CARGO NET

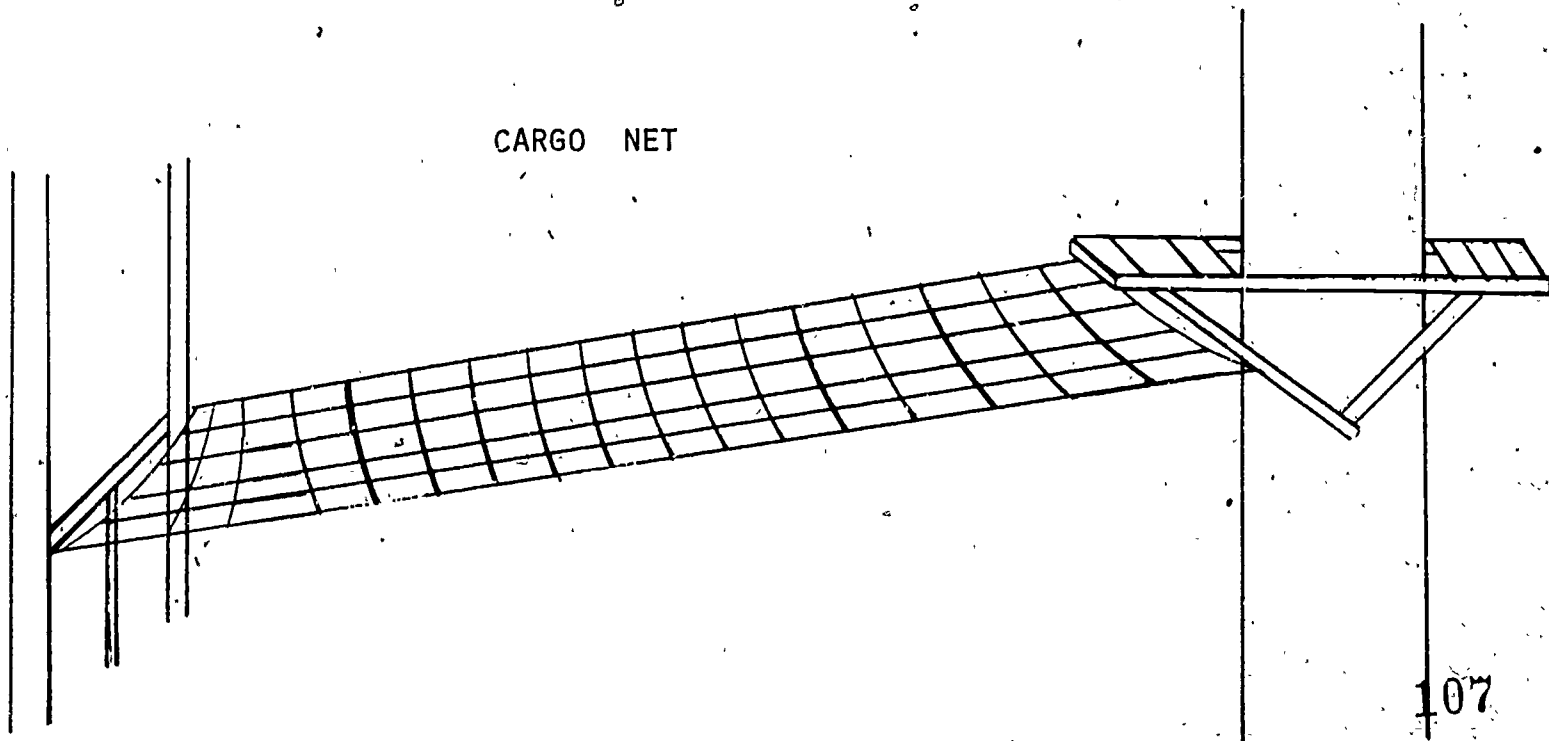

106

107

98
SKETCH # 1

Participants move across the webbing in a variety of ways. Some resemble a spider crossing its web. Those with good upper body strength tend to use their arms, others lay on their backs and push with their legs. Persons with severe quadraplegia sometimes enjoy being placed in the net and rocking back and forth.

To successfully complete this element the participant is challenged to identify and maximize individual strengths. Being able to work on balancing skills is another key benefit. Spotters protect from the sides and supervise from the elevated tree platform.

SWINGING TIRES (see Sketch #2)

Five tires approximately two feet apart are suspended by cable between two tree platforms. The tire interiors are padded to protect participants against abrasions. Participants can pass through the circular tires feet first or head first. Ambulatory participants may choose to step from middle to middle or cross along the tops.

A special benefit of this element is the need for participants to plan ahead. Spotters encourage the participant to maximize individual strengths when planning his/her route. The



Swinging tires with insolote padding transform an obstacle formerly negotiable only by ambulatory campers into a completely accessible activity.

The fourth tire is higher than the previous three which adds to the challenge. Spotter can add support and assistance to reduce difficulty where needed.

SADDLE LOGS (see Sketch #2)

Two logs strapped together are secured between two trees four feet above the ground. Participants can use rope loops hanging above the logs to assist in crossing the obstacle. Spotters follow on each side to encourage and protect.

CHAIR PULL (see Sketch #2)

The participant is strapped (seat and chest) in a suspended chair and pulls self along a fixed rope to the finishing platform. A seat belt and chest belt secure the participant in the adapted chair.

Most participants use their arms and pull along the rope. However, one participant used his feet to grab the rope when making the traverse. Spotters can reduce the difficulty by assisting with the locomotion. Participants enjoy the new sensation of floating in air.

PARALLEL TRAVERSE (see Sketch #3)

A specially adapted wheelchair rides along parallel cables with wheels about two feet above the ground. Additional cables run through holes drilled in the wheelchair arms to add stability. The tires

are removed from the wheels leaving a concave rim which conforms to the cable as the participant propels himself across the element. A seat belt is used to secure the participant.

Participants use arms and upper body to turn the wheels just like a regular wheelchair. Spotters can provide assistance if needed. As in the Inclined Balance Beam, ambulatory and non-ambulatory share the experience of using a wheelchair.



Parallel Traverse
"Great Stuff"

SWINGING TIRES

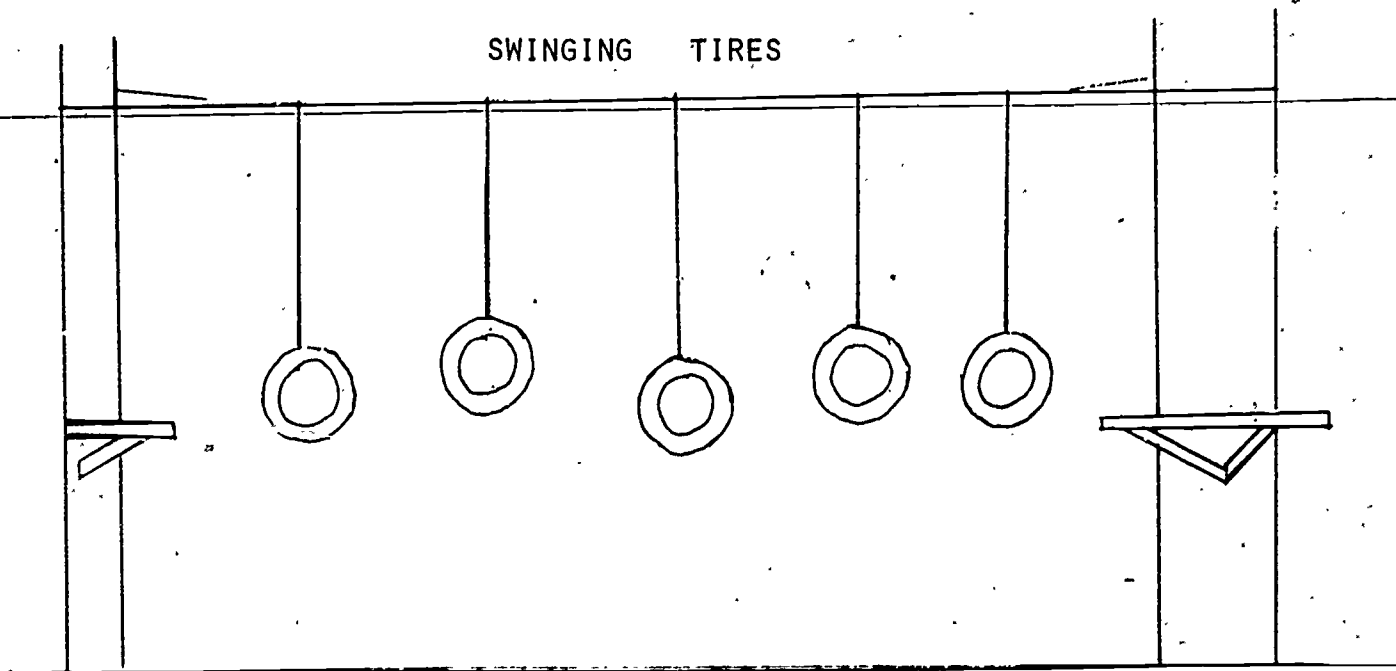

STRADDLE LOGS

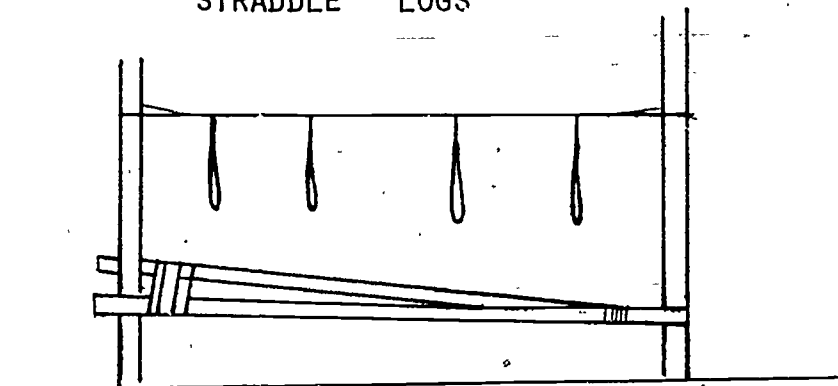

CHAIR PULL

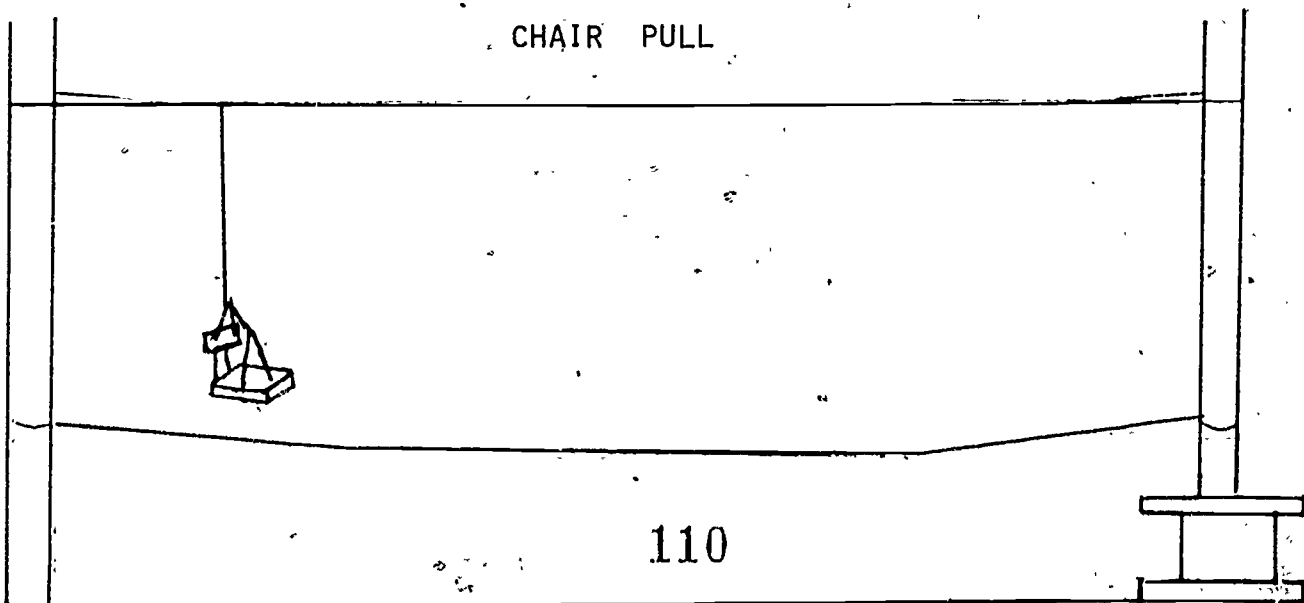

BURMA BRIDGE (see Sketch #3).

A single taut cable rises in elevation from two feet to five feet. Parallel ropes provide chest high handrails above the cable. Ambulatory participants walk up the cable using the parallel ropes for balance. Non ambulatory participants support their body weight with the ropes while spotters move the legs and feet along the cable. A safety line is attached to a seat harness worn by the participant to add protection in case of a slip.

TIPPY BRIDGE (see Sketch #4)

The Tippy Bridge moves in all directions; forward, backward, sideways, up, and down. The bridge is suspended at a height of five feet. A stabilizing rope attached under the platform can be tightened or loosened to vary the amount of movement.

The participant is hooked into a safety line and can crawl or walk across the bridge depending on individual abilities. In addition to testing balance skills, the height and movement of the bridge create a challenging mental obstacle.



"Tippy Bridge"



Sit harness allows all participants to experience "The Rings."

PARALLEL TRAVERSE

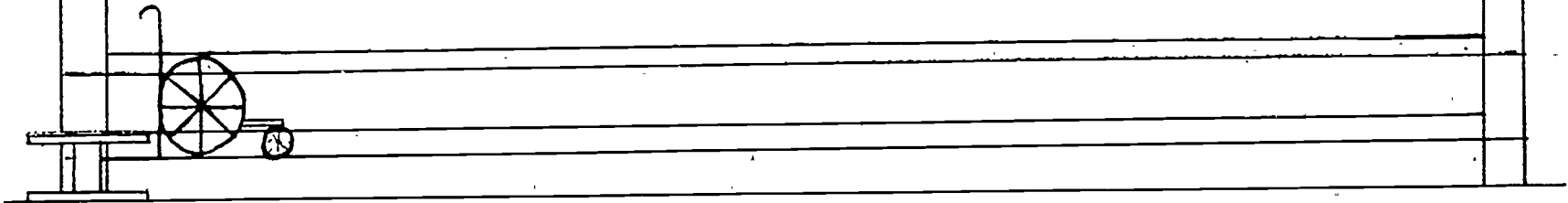

BURMA BRIDGE

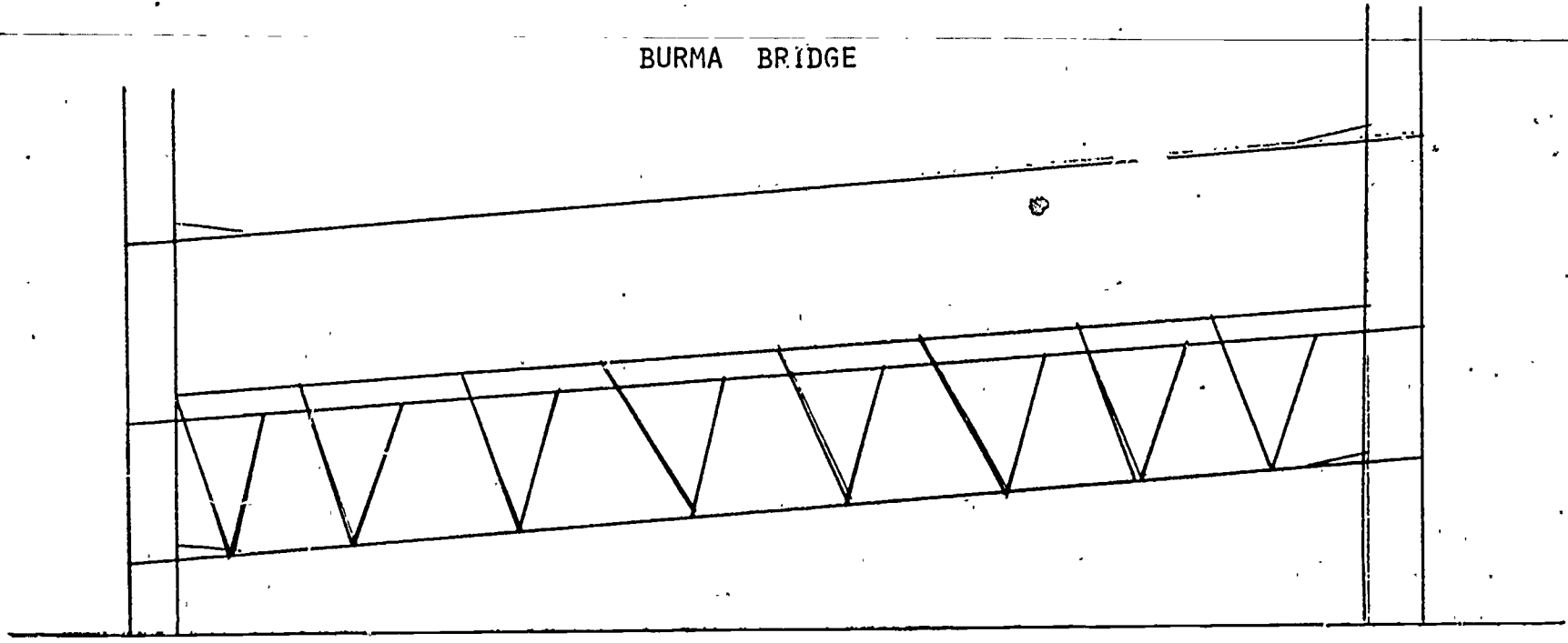

SKETCH # 3

103

112

113

THE RINGS (see Sketch #4)

Ten rings hang from parallel cables, five rings on each cable. A safety line is attached to the participant's seat harness for protection. The other end hooks into a pulley which rides on a cable above the rings.

The participants can keep the safety line slack and swing from ring to ring relying on arm strength. Or, the safety line can be tightened to support the participant's body weight. With minimal effort the pulley will slide along the cable as the participant pulls from ring to ring.

ZIP LINE (see Sketch #4)

An adapted chair similar to the one used in the Chair Pull runs along a cable from an elevated platform to a "landing area" thirty feet away. The participant is secured in the chair with a seat belt and chest belt. A safety line is attached to the individual as an additional safety measure.

This element does not require physical strength. Severely disabled participants may have trouble getting on the starting platform but otherwise all are capable of enjoying the Zip Line. The challenge is in overcoming the mental obstacles of fear and mistrust: trust in the spotters and the Zip Line design; and fear in the height and unknown. A successful experience on this element leaves the

participant with a new confidence to try new and challenging activities.



"Zip Line"

SUMMARY

It takes from 20 minutes to 90 minutes for participants to complete all ten elements. If there are enough spotters, three per participant, it is possible to have two participants on the course at the same time. Because of the length of time and number of required spotters, six is strongly recommended as the maximum group size.

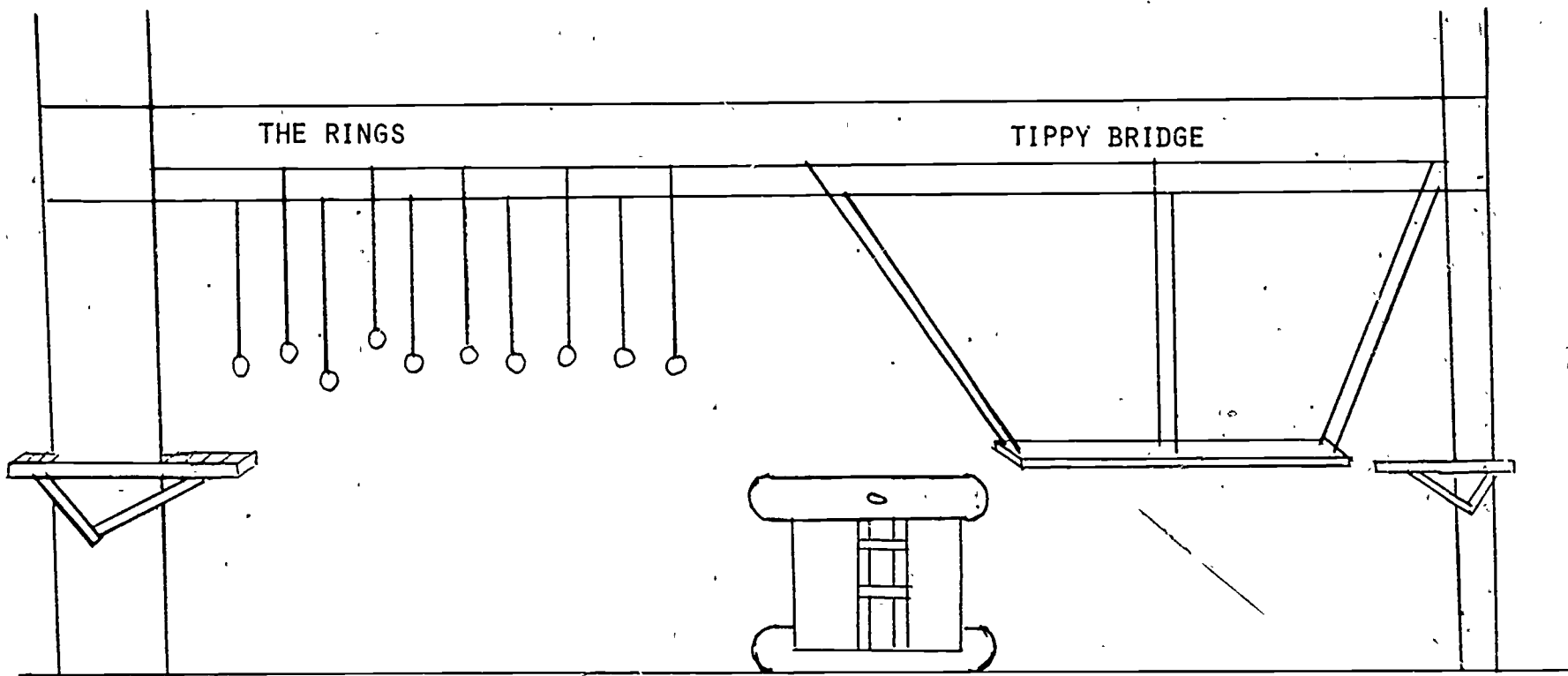

105
SKETCH # 4

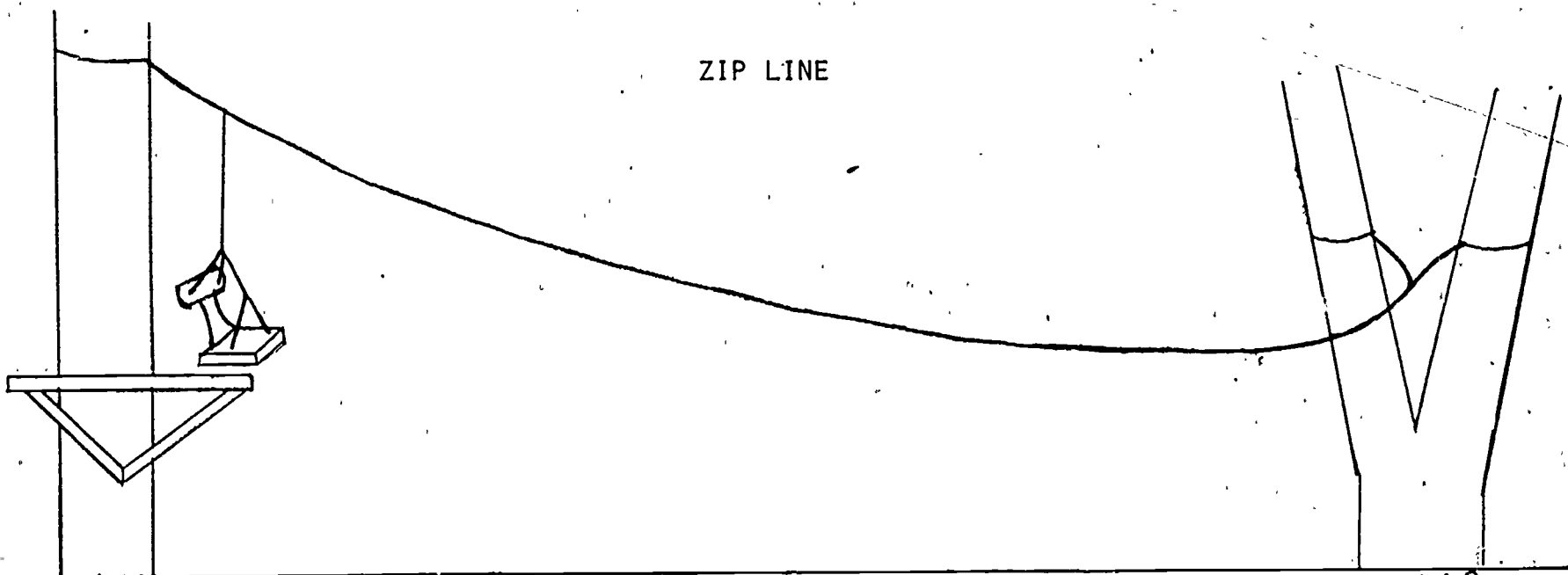

The new adapted ropes course has been a huge success. Teachers, staff, and participants have seen or experienced the course's high potential for growth. New and exciting benefits are discovered with each group that goes through the course and the integrative potential of this course is perhaps its greatest asset. The new adapted ropes course is just one more example of removing barriers to the barriers in allowing for maximum participation by all persons.

ADAPTED ROPES COURSE

BRADFORD WOODS, MARTINSVILLE, IND.

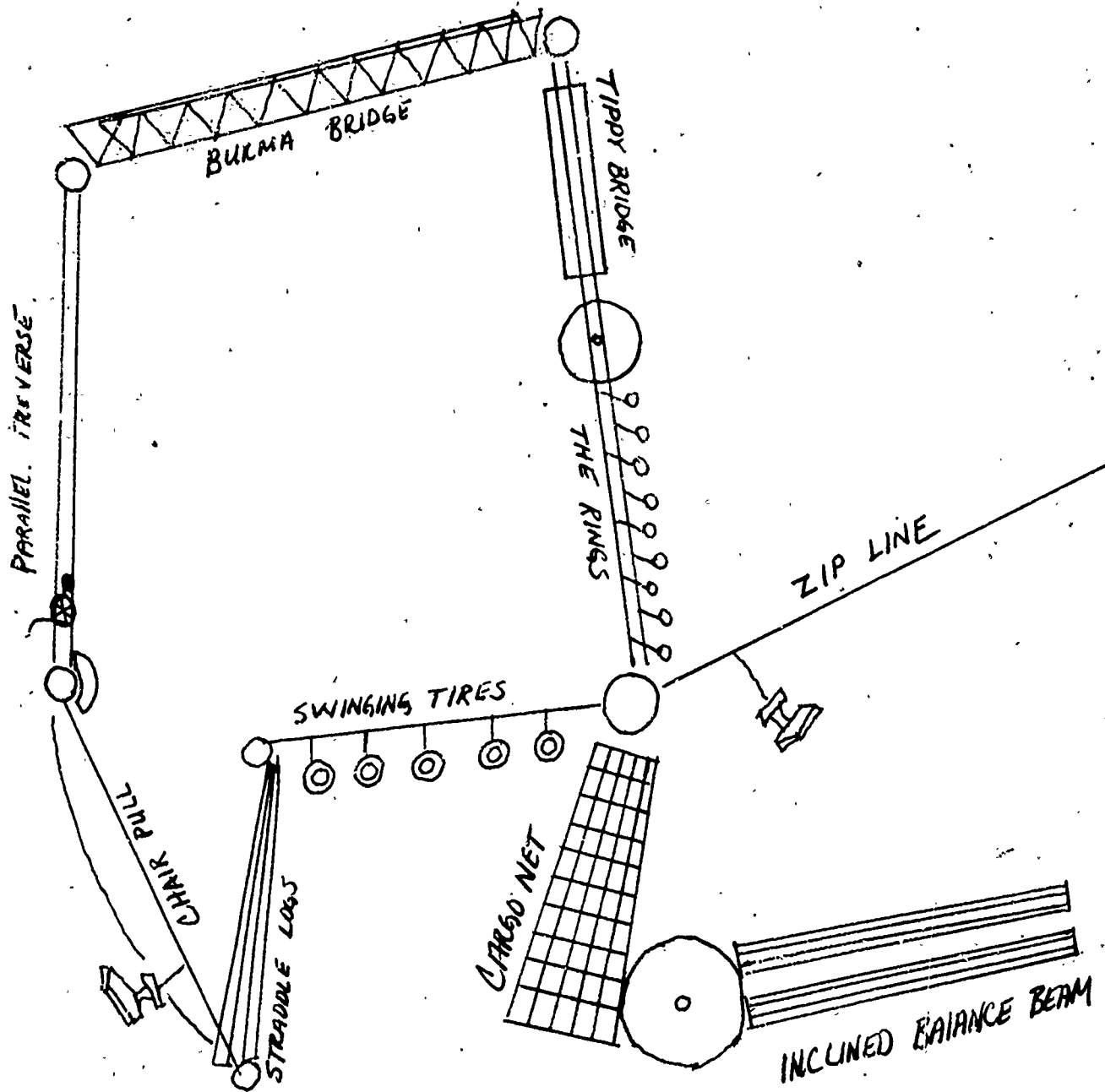

ACCESS RECREATION: DESIGNS AND PLANS

SILAS P. SINGH
SPRINGFIELD, ILLINOIS

EDITOR'S NOTE: Readers are advised that subsequent to submitting this article for publication Dr. Singh's position at the Illinois Department of Conservation was eliminated. Dr. Singh's contribution and advocacy on behalf of persons with disabilities within the State of Illinois will hopefully have lasting effect. However the Department of Conservation's commitment to serving the needs of persons with disabilities appears to have waned subsequently with this action. G. R.

Illinois, like many other states, has realized that many of the visitors to its state parks are in some way handicapped or disabled. In the past, there were few, if any, facilities or programs accessible to or usable by these individuals. The Illinois Department of Conservation (DOC) now is accomplishing an extensive renovation of its facilities and mainstreaming all visitors into its programs.

Spearheading this effort was my own appointment as Chief Program Development for the Department of Conservation, Bureau of Land and Historic Sites. I am a post-polio paraplegic confined to a wheelchair, experienced in recreation for the handicapped, as well as an avid sportsman.

Support for this program did not come easily from within the department. The major changes needed to accommodate individuals are not easily done and I needed the support of many professionals, park

maintenance personnel, as well as my superiors. For example, prior to my appointment to the Department of Conservation, some changes had to be made in the office building where I would work. First, the curbcut from the main entrance of the building had to be taken out and a new sloped entrance ramp installed. Second, the restroom needed grab bars installed and the stall door replaced. All of this confusion made the office staff become rather apprehensive about the new program. After all, who was this person who had the authority to insist upon the needed remodeling.

ACCESSIBILITY PLAN

Initially, a series of informational workshops for central office and administrative field employees was held to make them aware of the intense need to provide such facilities, for the handicapped and able-bodied alike.

Upon completion of the information workshops, we had convinced many employees of the need to provide accessible and usable facilities at as many state-owned properties as possible. The Department of Conservation established one site in each of its five administrative regions a Pilot Project Site for accessibility and usability by and for handicapped and elderly individuals. These sites now offer several recreational opportunities to the nation's next minority. Incidentally, in Illinois, this special group is certainly not a minority--there are presently over 2 million handicapped individuals residing in the state.

For the most comprehensive administration of the plan, I traveled throughout the state visiting DOC areas, inspecting facilities, and recommending changes. The cost for these changes usually came out of the individual site's budget. If funds were not available there, another service or program was cut, as this program was one of the Director's of the DOC's highest priorities.

The success of this program can be attributed to the strong support of both the Director of the DOC and the Illinois Governor. A state-wide plan to improve and increase recreational opportunities for the handicapped and elderly impaired individuals has

been developed and is currently being implemented. This plan is part of Illinois' State-Wide Comprehensive Outdoor Recreation Plan * (SCORP, 1977) which is required by law (Rehab. Act, 1973). The National Center for Law and the Handicapped in South Bend, Indiana, has designated Illinois' SCORP as a model plan for the nation (AMICUS, 1973).

The bottom line is that the Illinois Department of Conservation has made its employees very much aware of the needs of handicapped and elderly individuals and that everyone is working together to make facilities accessible to, usable by, and enjoyable for all citizens through mainstreaming (P. L. 94-142).

Areas guide brochure (available free), in concert with the mainstreaming concept, offers information regarding accessible and usable facilities for physically disabled individuals at all state parks and historic sites.

*This section of SCORP is based on the results of a project of the Office of Recreation and Park Resources and the Department of Leisure Studies, University of Illinois, Champaign, Illinois (Carol Ann Peterson, Project Director), under Illinois Department of Conservation Contract No. LR0006.

DESIGN STANDARDS MANUAL

Another facet of this development effort by the Department of Conservation has been the publication by the author of an extremely comprehensive, 48-page document entitled, "Mainstreaming Handicapped Individuals: Parks and Recreation Design Standards Manual." (Singh, 1978)

The manual is to enable persons with physical disabilities to pursue their recreational interests, develop their talents, and exercise their skills. It is written as a guide for the staff of the Illinois Department of Conservation in designing and constructing accessible buildings and parks in accordance with Section 504 of the Federal Rehabilitation Act of 1973.

The text describes the types of facilities and accommodations disabled visitors look for when they go to a state park.

Recommended criteria of accessibility for historic sites, camp sites, amphitheaters, and areas for picnics, swimming, boating, fishing, and games are presented. Specifications for parking, public telephones, toilet rooms, drinking fountains, walks, curbs, ramps, stairs, and entrances and exits in recreational areas are also provided. The attractive illustrations accompanying the text should be an incentive for handicapped persons and recreational planners to take full advantage of outdoor resources.



Pedestal grill provides easy access for wheelchair user.

The manual is developed to further the policy of the Illinois Department of Conservation---to encourage and promote the recreation of handicapped individuals in harmony with the recreational and stewardship roles of the Department. Implementation of the standards, consequently, is entrusted to a multi-disciplinary staff consisting of people from engineering, site planning, and park maintenance, which must not only adapt them carefully to the resource and operational determinants of locations and facilities, but also systematically select those areas, facilities, and programs to be brought into the mainstream.

The primary intent of the design standard is to eliminate, in so far as possible, unnecessary barriers encountered by aged, handicapped, or disabled persons, whose ability to engage in meaningful recreation or to achieve maximum personal independence is restricted needlessly when they cannot readily use park facilities.

INTERPRETIVE PROGRAMS

Accompanying the DOC's active commitment to making the state parks more accessible physically is an effort to plan, publicize, and conduct interpretative activities for all park visitors. (Singh, 1981) The focus of DOC's interpretive programming is the visiting family. Interspersed in the

family-oriented activities schedule are programs along topic or skill lines and/or for specific age categories.

Informal interpretive programs started in 1970. Formal interpretive activities started in 1978. The first interpretive programming that included mainstreaming practices were several trails. Several park interpreters completed courses in sign language to offer effective programs to deaf and hearing impaired persons. These interpreters and several others donate their own time in working with the institutionalized mentally and physically disabled individuals. Summer interpretive specialists have worked with the area's older adult groups in having the local "Meals on Wheels" program serve hot lunches in the local state park. The hot lunch is the incentive that attracts the older adults to participate in a day of activities in the park.

Interpretive Training Program

In order to program the accessible facilities with the interpretive aspect, DOC has planned a Interpreters Training Program (HIP). This program will be instituted as soon as funds are available. The HIP's goal is to train interpretive staffers in planning, conducting, and publicizing programs that will integrate handicapped visitors into park interpretive activities. Specific objectives of the program are:

- A. To train permanent interpreters.
- B. To train summer interpreters.
- C. To write a guide on "How to Prepare Interpreters to Work With Handicapped Visitors in Illinois Parks".
- D. To produce at least six half-hour video-tape programs dealing with various aspects of preparing, planning, conducting, and publicizing interpretive programs in the parks.
- E. Pre and post evaluations of the interpreters participating in the training program and the handicapped visitors attending the interpretive program in the parks.
- F. Conduct a national dissemination workshop in order to rapidly make available the guide and video-tape.

CONCLUSION

Individuals wishing to expand their horizons and to accomplish results in outdoor recreation need to work with disabled individuals at such outstanding sites as Bradford Woods, Martinsville, Indiana, and The Vinland National Center, Loretto, Minnesota. The staff at these centers, (and I'm sure there are others) know their job and do it well. The programs and procedures offered at these centers are based

on first hand experience and the combined research and recommendations of responsible sources, all of which have been carefully checked for accuracy and safety.

The DOC, on the other hand, offers many accessible and usable state parks and other facilities in Illinois, but is lacking in trained staff to offer meaningful programs for the benefit of physically handicapped and elderly impaired individuals. Accessible and usable outdoor recreation sites are good to have, but if these areas cannot offer realistic programs along with trained staff, then any responsibility for adverse effects or consequences resulting from the misapplication or injudicious use of any of the accessible sites or facilities would invariably rest on the shoulders of the responsible agencies.

The most encouraging thing about outdoor recreation is that disabled individuals are taking initiative to climb mountains and canoe uncharted streams-where one is challenged by the natural elements-is free from legal standard of compliance regarding architectural barriers. What the disabled person wants most of all is the opportunity to freely express his or her interaction with nature rather than being distracted with rules and regulations.



REFERENCES

"Illinois is Revamping its Outdoor Recreational Resources: A Statewide Comprehensive Plan", AMICUS, National Center for the Handicapped, 3, No. 3, May/June, 1978.

Jones, Michael A., Accessibility Standards, Illustrated, Capital Development Board, Springfield, Illinois, 1978.

Outdoor Recreation in Illinois: The Statewide Comprehensive Outdoor Recreation Plan: "Special Challenges: Outdoor Recreation for the Handicapped and Aging", Springfield, Illinois: State of Illinois, Department of Conservation, 1977.

Public Law 94-142, 94th Congress, Education for the Handicapped Act, Washington, D. C., 1975.

Rehabilitation Act,
Section 504 (as
ammended), 1973.

Singh, Silas P., "Adaptive
Facilities: Mainstreaming
Therapeutic Recreation",
Expanding Horizons in
Therapeutic Recreation,
IX, University of
Missouri, Columbia, 1981.

Singh, Silas P., Mainstreaming
Handicapped Individuals:
Parks and Recreation
Design Standards Manual,
Springfield, Illinois,
Illinois Department of
Conservation, 1978,
illus. paper.

OUTDOOR EDUCATION AND CAMPING CONFERENCE
COORDINATION: A COORDINATOR'S PERSPECTIVES

CHRISTINE SOPCZYNSKI
SOUTH BEND, INDIANA

EDITOR'S NOTE: In Volumes I and II of The Bradford Papers we highlighted evaluative comments of participants on various aspects of the Institute on Innovations in Camping and Outdoor Education With Persons Who Are Disabled. Instead of providing a similar report, we thought that readers might find interest in the perspective of a conference coordinator on the logistics of such an event. Ms. Sopczynski was the 1982 Institute Coordinator and the following highlights her insights.

Conference coordination is an extremely demanding experience and requires extensive planning and creativity to be successful. Not much has been written on the experiences of "conference planners" particularly in the camping and outdoor education profession. Most clearly because when it is over they wish to forget! Therefore, in planning a conference in camping and outdoor education previous participants, staff and coordinator evaluations serve as excellent tools for future planning.

Discussions with previous conference personnel can facilitate understanding of the overall conference operations. Adapting from business, conference coordination resources can stimulate creative ideas, however, in spite of using these resources, specific areas of conference planning in this field require further addressing.

The camping and outdoor education professionals who coordinate conferences will have certain strengths and

weaknesses in planning skills. For instance, because of their professional training, they may be highly skilled in proposing topics, but may lack the skills to adequately promote the conference. Also, by nature of their professional training, they may develop excellent conference leisure activities, but may have difficulty determining conference budgets. To be discussed are areas of conference coordination in which camping and outdoor professionals may be deficient, and what this author sees as important areas of conference planning. These observations are based upon personal experiences as Coordinator of the 1982 Institute on Innovations In Camping and Outdoor Education With Persons Who Are Disabled.

One area to be addressed is the development of possible conference session topics. Novel ways to create topics should be used. An example is the utilization of colleagues as a networking

system to provide information on recent developments in the field that conference participants would find interesting. Also, these individuals could participate in a brainstorming session in which creative subjects could be devised. Reviewing articles from related professional journals and various agency newsletters will further stimulate new session topics. During a brainstorming session, general subjects to consider include new trends, political implications, funding sources, legal trends, administrative concerns, staff development, programming methods, techniques, practitioner needs, client needs and research.

The conference coordinator and director must also be assured that their speakers give quality presentations. By requesting a copy of the speaker's speech and presentation format, the contents of the speaker's presentation can be adequately determined. Also, it is important that each speaker know what is expected, and that the goals of the conference be met. Methods to make a presentation unique and stimulating should be suggested to the speaker. In sessions that are not action/participant oriented, presentors need to find creative ways to maintain audience interest. One suggestion is that the speaker alternate five to ten minutes of talking with questions. Other means of keeping audiences interested are the use of a variety of audiovisual materials and other audience participation

methods, such as a debate format which presents various aspects of an issue. Remember, an audience's attention span during a speech is usually twenty minutes, so the speaker should plan within that time frame.

A common problem with speakers is delays in accepting invitations to speak. Consequently, it is crucial to establish and stress a deadline for acceptance and the submission of proposals. The effects of noncompliance with these deadlines are conference sessions that cannot be finalized and incomplete promotional materials on session content.

When coordinating conferences on outdoor education and camping, the coordinator must be aware that pressure periods occur. An example of a pressure period is sending the conference press releases within the required time. Most press releases, in order to be published in journals and newsletters, must be sent five months in advance. It is of the utmost importance that these press releases be mailed on time. If bulk mailings are implemented, this too can be a pressure period. Bulk mailing is a lengthy process and may take as long as two weeks to deliver. So, ample time should be allotted. Another pressure period two to three weeks prior to the conference is the "preconference rush," where mass registrations arrive and require time for processing. This rush is further complicated for the

coordinator if he/she is processing these registrations and finalizing last minute conference details at the same time.

The previously mentioned problem of speakers not submitting their session proposals by an established deadline, can also develop into a pressure period. If transportation from airports or bus stations is being provided to the conferees, confusion can occur and result in another pressure period. This happens because conference participants will often phone at the last minute and request transportation. The individual who coordinates transportation should remain flexible and anticipate changes in transportation scheduling. A final pressure period can result when speakers request, just prior to their presentation, changes in audiovisual equipment. Such changes can severely alter the often strategically planned rotation schedule of audiovisual equipment. To minimize this probability, it is suggested that additional audiovisual equipment be available. Screens and slide projectors are often last minute request items.

In the area of promotions, camping and outdoor professionals often lack skills to adequately promote an activity, because they lack a marketing background. In addition, promotions can be costly and today's tight budgets do not allow for expenditure in this area. It is anticipated that most people are unaware that national mailings must be made three times to provide major results. Mailing threefold is not only time consuming, but also expensive.

Another important aspect of promotions, but not often recognized by professionals, is the application of a logo. A logo should be used on all conference materials in conjunction with a complimentary color theme. In addition to placing a logo on all written conference materials, it can be creatively placed on banners, backdrops, cocktail glasses and bathroom mirrors. Having a logo displayed in unusual places provides theme continuity throughout the conference.

The date for the next year's conference should also be publicized and this can be done in various ways. It can be written on a banner and displayed on the final days of the conference, printed at the end of the conference booklet and posted in traffic areas such as a message board.

An area of conference planning needing brief mention is that of the steering or planning committee. Since steering committees often consist of persons nationwide who are not readily accessible to conference planners, it can be difficult to utilize them in the planning stages. However, this committee can be effective during the conference by attending daily conference progress meetings. At these meetings, they can serve as facilitators during sessions by leading discussions and asking questions. Utilizing committee members in this fashion can be beneficial, especially if there is a lull in a presentation.

Fortunately, there are various resources to assist conference planners on budget development. The local Chamber of Commerce can provide the

available community resources on conference budgets. Continuing education programs, conference bureaus and library books on conference coordination are other useful resources.

In conclusion, camping and outdoor education conference planners who recognize all of these critical areas of conference coordination, can ensure a more smoothly run and professional quality conference. Being aware of pressure periods allows the conference planners to be prepared for tense situations. Recognizing the necessity of obtaining speech copies and presentation outlines increases the probability of a good presentation. Appropriately promoting the conferences by using a logo, consistent color theme and other types of publicity such as frequent mailings provides an added professional flair. By adequately addressing these areas of conference coordination, the conference planners can achieve success.

REFERENCES

- American Society of Association Executives, MAKING YOUR CONVENTIONS MORE EFFECTIVE, Washington, D. C.: American Society of Association Executives, 1972.
- Bieber, M., HOW TO RUN A CONFERENCE, England: George Allen and Unwin, Ltd., 1968.
- Finkel, C., PROFESSIONAL GUIDE TO SUCCESSFUL MEETINGS, Boston, Mass.: Herman Publishing, Inc., 1976.

Hart, L. B. & Schulcher, J. G., A CONFERENCE AND WORKSHOP PLANNER'S MANUAL, New York: AMACOM, A division of American Management Association, 1979.

Loft, V. (ed.), CONVENTION LIASON MANUAL, New York: Convention Liason Committee, American Hotel and Motel Association, 1972.

Lord, R. W., RUNNING CONVENTIONS, CONFERENCES, AND MEETINGS, New York: AMACOM, A Division of American Management Association, 1981.

Nadler, L. & Nadler, Z., THE CONFERENCE BOOK, Houston, Texas: Gulf Publishing Co., 1977.

1982 INSTITUTE STAFF

INSTITUTE DIRECTOR: GARY M. ROBB

INSTITUTE COORDINATOR: CHRISTINE SOPCZYNSKI

INSTITUTE SECRETARY: VICKIE W. ROBB

INSTITUTE PLANNING COMMITTEE:

DALE ABELL
HOWARD COHEN
ED HAMILTON
JERRY HITZHUSEN
CHRIS ROLAND
TOM SMITH
NORMA STUMBO
WAYNE VAUGHN

STEVE BRANNAN
JOHN GALLAND
MARK HAVENS
MARY MCCARTHY
TOM SHEA
DEBORAH STUART
GARY THOMPSON
JEFF WITMAN

BRADFORD WOODS OUTDOOR EDUCATION, RECREATION AND CAMPING CENTER STAFF:

GARY M. ROBB, DIRECTOR
DONALD J. BROWN, ASSISTANT DIRECTOR
MARCIA JEAN CARTER, COORDINATOR, SPECIAL POPULATIONS
THOMAS E. BARHAM, COORDINATOR OUTDOOR EDUCATION
MARY ARNOLD, FOOD SERVICE SUPERVISOR
BARBARA BEARD, COOK
MAX WILSON, MAINTENANCE SUPERVISOR
LEONARD ALVEY, MAINTENANCE
DONALD CALLAHAN, MAINTENANCE
MARY FAETH CHENERY, COORDINATOR, ACADEMIC PROGRAMS
BRENDA FARMER, ADMINISTRATIVE CLERK
PATTI KOHLER, POST GRADUATE INTERN
PAULA WEBBER, POST GRADUATE INTERN
TOM HUSSMAN, ASST. DIRECTOR, SUMMER CAMP PROGRAMS
LITA BUSH, INTERN
LAURA MCCAMMON, INTERN
LISA MASTER, INTERN
CLAUDIA MEY, INTERN
THAYER RAINES, ASSOCIATE INSTRUCTOR
CHRISTINE SOPCZYNSKI, ASSOCIATE INSTRUCTOR
STAFFAN KLEINER, INTERNATIONAL EXCHANGE (SWEDEN)
KARL SWENSON, ASSOCIATE INSTRUCTOR
CANDICE RAINES, ASSOCIATE INSTRUCTOR
MICHAEL OGDEN, INTERNATIONAL INTERN (LEEDS POLYTECHNIC)
JEFFREY SHIELDS, INTERNATIONAL INTERN (LEEDS POLYTECHNIC)
JONATHAN BROWN, INTERNATIONAL INTERN (LEEDS POLYTECHNIC)
HELEN DOBBS, HOUSEKEEPING
CAROLYN HAM, HOUSEKEEPING